

WHEELER-REX

www.wheelerrex.com



OVER **50** YEARS
of product excellence

PROFESSIONAL TOOL CATALOG

WHEELER-REX

new products

New!



New!

5195 ECONOMY SNIPPERS
Page 39



New!

5295 ECONOMY SNIPPERS
Page 39



New!

6600 MANUAL ROLL GROOVER
Page 12



New!

9700 HYDRAULIC ROLL GROOVER WITH BASE
Page 12



New!
DESIGN

1694 GUILLOTINE PIPE CUTTER
Page 43



New!

5690, 5691 & 5692 AUTO-C CUTTERS
Page 33



New!

50100 INNER/OUTER REAMER
Page 36



New!

8090 PIPE THREADING MACHINE
Page 19



New!

62000 NIPPLE ATTACHMENTS
Page 21

PROFESSIONAL TOOL CATALOG



Phone _____
(440) 998-2788
8:00 a.m. to 4:30 p.m. Eastern Standard Time
Toll-Free _____
1-800-321-7950
Fax _____
(440) 992-2925
Web _____
www.wheelerrex.com
E-mail _____
wheeler@wheelerrex.com

Follow us on Facebook,
Twitter & LinkedIn

To expedite telephone orders,
please have your customer
number ready. We accept Visa,
Mastercard and Discover.

TABLE OF CONTENTS

Pipe Cutters	Pages 4–11	Glass Tube Cutters	Page 38
Manual & Ratchet Snap Cutters	Steel Pipe Cutters	Cutters for glass tubing	
Soil Pipe Coupling Torque Wrenches	Hinged Pipe Cutters	Plastic Pipe Tools	Pages 39–43
Hydraulic Pipe Cutters	Pipe Cleaner	Professional & Economy Snippers	Pipe Hog® and Kit
Hydraulic Pump Fluid	KwikSnap	Blade Sharpener	Pipe Fitting Savers and Kit
Replacement Cutter Chains	KwikSnap Table	Hand Saws	Internal Cutters
Internal Cast Iron Pipe Cutter	The PipeMaster	Cable Saws	Chamfering/Depth Gauge Tool
Grooving & Fabrication	Pages 12–15	Hand and Powered Bevelers	Guillotine Pipe Cutters
Manual Roll Groover	Hydraulic Roll Grooving Accessories	Pipe Working Tools	Pages 44–45
Portable Roll Groovers	Orbital Pipe Cutting Machine	Tripod Vise Stand	Pipe Puller
Hydraulic Roll Grooving Machines	Mantis™ Band Saws	Folding Tripod Pipe Supports	Plug Popper
12R Style Replacement Dies and Die Heads	Pages 16–17	Yoke Vises	Pipe Dolly
Manual Ratchet Threader Sets	12R Style Dies – NPT, BSPT, NPSM	Floor Pipe Vises	
Mini Power Drives	12R Style Drop Head with Dies	Shut-Off Tools	Page 46
Hand Oiler	– NPT, BSPT, NPSM	For Soft Copper Water Lines	For Plastic Water and Gas Lines
Pipe Threading Machines	Pages 18–20	Pipe Freezing Kit	Page 47
Sidekick II Pipe Threader	Cutting and Beveling Machines	Pipe Freezing Kit	Replacement Polar Spray
Power Threading Machines		Drilling and Tapping Tools	Pages 48–51
Threading Accessories & Cutting Fluid	Pages 21–26	Hot Tap System & Accessories	Hole Cutter System and Shells
Threader Carts	ThreadMaster Threading Fluid	Drill Taps	Earthworm Hydro-Drill
Nipple Attachments	Wheeler-Rex Replacement Dies / Die Heads	Tapping Fluid	Pipe Slices & Accessories
Sidekick II Threader Stand		Portable Hole Cutter Systems	Mini Pipe Slice
Universal Replacement Dies	Page 27	Valve Exercisers	Pages 52–53
Universal Die Head	Pipe Dies for Universal Heads	ValveMaster	Rising Stem & Hand-Wheel Adapters
Hydrostatic Test Pumps	Pages 28–31	Portable Valve Exercisers	Telescoping Valve Keys
Manual Operated	Pneumatic Operated	Wrenches, Pliers & Fastening Tools	Pages 54–57
Gas Operated	Fire Hose Testers	Pipe Wrenches	No-Hub® Coupling Wrenches
Electric Operated	Vacuum Test Assembly	GripMaster	Basin Wrench
Trash Pumps	Page 32	Spud Wrench	Strap Wrenches
2" and 3" Trash Pumps	Mudsucker Pumps	Double-Up Wrenches	Valve Wheel Wrenches
4" Trash Pump		Heavy Duty Deep Sockets	Hydrant Wrench
Tube Tools	Pages 33–36	TwinTites™	Chain Wrench
Auto-C Cutters	Inner & Outer Reamer	Coupling Torque Wrenches	Utility Pliers
Close Quarter Cutter	Deburring Tool	Crimping Tools	Pages 58–59
Tube Brushes	Hammerhead Flaring Tool	PEX Crimping Tools	
Ratch Cuts and Kits	Rerounding Tools and Kit	Miscellaneous Tools	Page 60
Tube Tools		Hack Saws	O.D. Tapes
Replacement Cutter Wheels	Page 37	6-in-1 Screwdrivers	
Replacement Cutter Wheels		Distributor Marketing Aids	Page 61
		Product Index	Pages 63–66

PIPE CUTTERS



590 AND 591 MANUAL PIPE CUTTER

Wheeler #	Service (Std) WT Soil Pipe	XH Soil Pipe	No-Hub®	Tile / Clay	Weight
590-6	1½"-6" (38mm-150mm)	1½"-5" (38mm-125mm)	1½"-6" (38mm-150mm)	4"-6" (100mm-150mm)	23 lbs. (10.5kg)
590-8	1½"-6" (38mm-150mm)	1½"-5" (38mm-125mm)	1½"-6" (38mm-150mm)	4"-8" (100mm-200mm)	25 lbs. (11.5kg)
590-10	1½"-6" (38mm-150mm)	1½"-5" (38mm-125mm)	1½"-6" (38mm-150mm)	4"-10" (100mm-250mm)	27 lbs. (12.5kg)
590-12	1½"-6" (38mm-150mm)	1½"-5" (38mm-125mm)	1½"-6" (38mm-150mm)	4"-12" (100mm-300mm)	28 lbs. (12.7kg)
590-15	1½"-6" (38mm-150mm)	1½"-5" (38mm-125mm)	1½"-6" (38mm-150mm)	4"-15" (100mm-375mm)	29 lbs. (13kg)
591-6	1½"-6" (38mm-150mm)	1½"-5" (38mm-125mm)	1½"-6" (38mm-150mm)	4"-6" (100mm-150mm)	24 lbs. (11kg)
591-8	1½"-6" (38mm-150mm)	1½"-5" (38mm-125mm)	1½"-6" (38mm-150mm)	4"-8" (100mm-200mm)	25 lbs. (11.5kg)



Close-up view of "captured screw"



490 AND 491 RATCHET PIPE CUTTER



Wheeler #	Service (Std) WT Soil Pipe	XH Soil Pipe	No-Hub®	Tile / Clay	Weight
490-6	1½"-6" (38mm-150mm)	1½"-5" (38mm-125mm)	1½"-6" (38mm-150mm)	4"-6" (100mm-150mm)	18 lbs. (8.5kg)
490-8	1½"-6" (38mm-150mm)	1½"-5" (38mm-125mm)	1½"-8" (38mm-200mm)	4"-8" (100mm-200mm)	19 lbs. (8.6kg)
490-10	1½"-6" (38mm-150mm)	1½"-5" (38mm-125mm)	1½"-8" (38mm-200mm)	4"-10" (100mm-250mm)	20 lbs. (9.5kg)
490-12	1½"-6" (38mm-150mm)	1½"-5" (38mm-125mm)	1½"-8" (38mm-200mm)	4"-12" (100mm-300mm)	22 lbs. (10kg)
490-15	1½"-6" (38mm-150mm)	1½"-5" (38mm-125mm)	1½"-8" (38mm-200mm)	4"-15" (100mm-375mm)	23 lbs. (10.5kg)
491-6	1½"-6" (38mm-150mm)	1½"-5" (38mm-125mm)	1½"-6" (38mm-150mm)	4"-6" (100mm-150mm)	18 lbs. (8.5kg)
491-8	1½"-6" (38mm-150mm)	1½"-5" (38mm-125mm)	1½"-8" (38mm-200mm)	4"-8" (100mm-200mm)	19 lbs. (9kg)

- 6519 ½" Square Male/Female Drive Ratchet..... 2 lbs. (.9kg)
- 700669 Replacement Drive Screw Assembly

3990 XH RATCHET PIPE CUTTER

Wheeler #	Service (Std) WT Soil Pipe	XH Soil Pipe	Tile / Clay	Cast Iron Water Class 22	Weight
3990-6	2"-6" (50mm-150mm)	2"-6" (50mm-150mm)	2"-6" (50mm-150mm)	2"-6" (50mm-150mm)	19 lbs. (9kg)
3990-8	2"-8" (50mm-200mm)	2"-8" (50mm-200mm)	4"-8" (100mm-200mm)	2"-6" (50mm-150mm)	20 lbs. (9.5kg)

- 6520 ½" Square Female Drive Ratchet – U.S.A. Made 2 lbs. (.9kg)
- 700919 Replacement Drive Screw Assembly

SOIL PIPE COUPLING TORQUE WRENCH

This durable "T-Handle" type torque tool with a contoured comfort-fit handle features a removable socket and a unique locking collar, which allows the tool to be used as an untorqued snug-up or back-off, as well as a conventional torque tool. With the locking collar retracted, the tool torques to the right (tightening), while ratcheting to the left. When proper torque value has been achieved, the mechanism slips internally and over-tightening is impossible.

- 1977 T-Torque for tightening 5/16" coupling nuts to 60 in. lbs..... Weight 1 lb. (.5kg)
- 1980 T-Torque for tightening 5/16" coupling nuts to 80 in. lbs..... Weight 1 lb. (.5kg)
- 1981 T-Torque for tightening 3/8" coupling nuts to 80 in. lbs..... Weight 1 lb. (.5kg)
- 1982 T-Torque for tightening 5/16" & 3/8" coupling nuts to 80 in. lbs..... Weight 1 lb. (.5kg)
- 275410 5/16" Replacement Socket
- 275818 3/8" Replacement Socket



Replaceable Socket →

More Torque Wrenches available... see page 56.



WHEELER-REX HYDRAULIC CUTTERS

Wheeler-Rex Hydraulic Cutters are the solution to cutting larger diameter Cast Iron, Tile and Concrete Pipe. Like the hand operated “snap” cutters, hydraulic cutters are not rotated around pipe. Their remotely operated hydraulic pumps provide the required power. A 2”–3” minimum clearance is all that is needed to wrap cutter chain around pipe. They come complete with pump, hose and case.



2990 HYDRAULIC PIPE CUTTER

Wheeler #	Service (Std) WT Soil Pipe	XH Soil Pipe	Tile / Clay	Cast Iron Water Class 22	Cast Iron Water Class 26	Weight
2990-6	2”–6” (50mm–150mm)	2”–6” (50mm–150mm)	2”–6” (50mm–150mm)	2”–6” (50mm–150mm)	NA	85 lbs. (.39kg)
2990-8	2”–8” (50mm–200mm)	2”–8” (50mm–200mm)	2”–8” (50mm–200mm)	2”–6” (50mm–150mm)	NA	87 lbs. (.40kg)
2990-10	2”–10” (50mm–250mm)	2”–8” (50mm–200mm)	2”–10” (50mm–250mm)	2”–6” (50mm–150mm)	NA	89 lbs. (.41kg)
2990-12	2”–10” (50mm–250mm)	2”–8” (50mm–200mm)	2”–12” (50mm–300mm)	2”–6” (50mm–150mm)	NA	92 lbs. (.42kg)
2990-15	2”–10” (50mm–250mm)	2”–8” (50mm–200mm)	2”–15” (50mm–375mm)	2”–6” (50mm–150mm)	NA	94 lbs. (.43kg)



3890 HYDRAULIC PIPE CUTTER

Wheeler #	Service (Std) WT Soil Pipe	XH Soil Pipe	Tile and Concrete	Cast Iron Water Class 22	Cast Iron Water Class 26	Weight
3890-12	4”–12” (100mm–300mm)	4”–12” (100mm–300mm)	4”–12” (100mm–300mm)	4”–12” (100mm–300mm)	4”–10” (100mm–250mm)	157 lbs. (.72kg)
3890-15	4”–15” (100mm–375mm)	4”–15” (100mm–375mm)	4”–15” (100mm–375mm)	4”–12” (100mm–300mm)	4”–10” (100mm–250mm)	163 lbs. (.74kg)
3890-18	4”–18” (100mm–450mm)	4”–18” (100mm–450mm)	4”–18” (100mm–450mm)	4”–12” (100mm–300mm)	4”–10” (100mm–250mm)	170 lbs. (.77kg)
3890-24	4”–18” (100mm–450mm)	4”–18” (100mm–450mm)	4”–24” (100mm–600mm)	4”–12” (100mm–300mm)	4”–10” (100mm–250mm)	178 lbs. (.88kg)



5590 HYDRAULIC PIPE CUTTER

Wheeler #	Service (Std) WT Soil Pipe	XH Soil Pipe	Tile and Concrete	Cast Iron Water Class 22	Cast Iron Water Class 26	Weight
5590-18	6”–18” (150mm–450mm)	6”–18” (150mm–450mm)	6”–18” (150mm–450mm)	6”–18” (150mm–450mm)	6”–18” (150mm–450mm)	200 lbs. (.91kg)
5590-20	6”–18” (150mm–450mm)	6”–18” (150mm–450mm)	6”–20” (150mm–500mm)	6”–20” (150mm–500mm)	6”–18” (150mm–450mm)	213 lbs. (.97kg)
5590-24	6”–18” (150mm–450mm)	6”–18” (150mm–450mm)	6”–24” (150mm–600mm)	6”–20” (150mm–500mm)	6”–18” (150mm–450mm)	230 lbs. (105kg)
5590-36	6”–18” (150mm–450mm)	6”–18” (150mm–450mm)	6”–36” (150mm–900mm)	6”–20” (150mm–500mm)	6”–18” (150mm–450mm)	269 lbs. (122kg)



HYDRAULIC PUMP FLUID

(Wheeler Hydraulic Cutter guarantees valid only when Hydroyl fluid is used.)

3801	1 Qt.	2 lbs. (.9kg)
3804	1 Gal.	8 lbs. (4kg)

Gallons are available in cases of six.

PIPE CUTTER CHAINS



490 RATCHET, 590 MANUAL & 1790 JR. HYDRAULIC

Part No.		Length	No. of pins	Weight
522	Chain for 6" Pipe	26 1/4"	21	5 lbs. (2.3kg)
532	Chain for 6" Pipe with rollers for No-Hub®	26 1/4"	21	5 lbs. (2.3kg)
528	Chain for 8" Pipe	36"	29	7 lbs. (3kg)
533	Chain for 8" Pipe with rollers for No-Hub®	36"	29	8 lbs. (3.6kg)
5210	Chain for 10" Pipe	43 3/4"	35	8 lbs. (3.6kg)
5212	Chain for 12" Pipe	51"	41	10 lbs. (4.5kg)
5215	Chain for 15" Pipe	58 1/2"	47	11 lbs. (5kg)
FOR CONVERTING YOUR PRESENT CHAIN TO CUT LARGER SIZES				
5256	6" to 8", 8" to 10", 10" to 12", 12" to 15"	10"	8	2 lbs. (.9kg)
5258	6" to 10", 8" to 12", 10" to 15"	17 1/2"	14	4 lbs. (1.8kg)
52510	6" to 12", 8" to 15"	25"	20	5 lbs. (2.3kg)
52512	6" to 15"	32 1/2"	26	6 lbs. (2.7kg)
519	Kit to convert 590 Cutter to 591 No-Hub® Cutter or 490 Cutter to 491 No-Hub® Cutter			

3990 RATCHET PIPE CUTTER

Part No.		Length	No. of Pins	Weight
700987	Chain for 6" Pipe	26"	21	7 lbs. (3kg)
701077	Chain for 8" Pipe	36"	29	8.5 lbs. (3.8kg)

2990 HYDRAULIC CUTTER

Part No.		Length	No. of pins	Weight
1926	Chain for 6" Pipe	26 1/4"	21	7 lbs. (3kg)
1924	Chain for 8" Pipe (replaces 2924)	36 1/4"	29	8 1/2 lbs. (3.8kg)
192410	Chain for 10" Pipe (replaces 292410)	46 1/4"	37	11 lbs. (5kg)
192412	Chain for 12" Pipe (replaces 292412)	53 1/4"	43	13 lbs. (5.9kg)
192415	Chain for 15" Pipe (replaces 292415)	61 1/4"	49	15 lbs. (6.8kg)
FOR CONVERTING YOUR PRESENT CHAIN TO CUT LARGER SIZES (Note - Old and new style chain extensions NOT interchangeable)				
19010	8" Cutter to 10"	10"	8	2 1/2 lbs. (1kg)
19012	8" Cutter to 12"	17 1/2"	14	4 1/2 lbs. (2kg)
19015	8" Cutter to 15"	25"	20	6 1/2 lbs (2.9kg)
2905	Adjusting link for 2990 Chain			

3890 HEAVY DUTY HYDRAULIC CUTTER

Part No.		Length	No. of pins	Weight
3824	Chain for 12" Pipe	50 3/4"	29	24 lbs. (10.9kg)
382415	Chain for 15" Pipe	63"	37	31 lbs. (14kg)
382418	Chain for 18" Pipe	76 1/2"	43	35 lbs. (15.9kg)
382424	Chain for 24" Pipe	97 1/2"	55	46 lbs. (20.9kg)
FOR CONVERTING YOUR PRESENT CHAIN TO CUT LARGER SIZES				
382515	12" Cutter to 15"	14"	8	7 lbs. (3kg)
382518	12" Cutter to 18"	24 1/2"	14	11 lbs. (5kg)
382520	12" Cutter to 20"	35"	20	11 lbs. (5kg)
382524	12" Cutter to 24"	46 1/2"	26	22 lbs. (10kg)

5590 SUPER HYDRAULIC CUTTER

Part No.		Length	No. of pins	Weight
5524	Chain for 18" Pipe	72 1/2"	29	70 lbs. (31.8kg)
552420	Chain for 20" Pipe	82 1/2"	33	80 lbs. (36.4kg)
552424	Chain for 24" Pipe	97"	39	95 lbs. (43.2kg)
552436	Chain for 36" Pipe	142"	57	134 lbs. (60.9kg)
FOR CONVERTING YOUR PRESENT CHAIN TO CUT LARGER SIZES				
552520	18" Cutter to 20"	10"	4	10 lbs. (4.5kg)
552524	18" Cutter to 24"	25"	10	25 lbs. (11.4kg)
552536	18" Cutter to 36"	70"	28	64 lbs. (29.1kg)

NOTE: Hydraulic cutter chain parts: individual pins, links and wheels are only available with factory installation. Hydraulic cutter chain extensions are available only through authorized service stations unless installed by the factory.

PIPE CUTTERS

CONTINUED



INTERNAL CAST IRON PIPE CUTTER (CAPITOL STYLE CUTTER)

Cuts Cast Iron from the inside out!!

Designed to eliminate the difficulty plumbers have in setting toilet bowls, urinals and similar fixtures due to the shortness of the closet horn. Make cuts where nothing else can!

32900	3" Cast Iron.....	14 lbs. (6kg)
42900	4" Cast Iron.....	16 lbs. (7kg)

Replacement Cutter Wheels:

700201	Cutter Wheel for CI for 32900/42900
--------	-------------------------------------



STEEL PIPE CUTTERS

Two models designed for fast, easy cutting of steel pipes. Both models come with an extra long shank which protects adjustment threads and an extra large handle for quick, easy adjustment.

2690	For 1/8"-2" steel pipe	5.6 lbs. (2.5kg)
8081	Cutter Wheel for steel	
8082	Cutter Wheel for stainless steel	
4690	For 2"-4" steel pipe.....	17.5 lbs. (7.9kg)
8016	Cutter Wheel for steel	
8004	Cutter Wheel for stainless steel	



HINGED PIPE CUTTER

Four-wheel cutter, featuring a unique guide bar design that ensures both smooth operation and accurate precise pipe cutting. Needs only 90° to 110° handle swing, and only 4 inch clearance. Universal cutter wheels are ideal for cutting most metals and are interchangeable with many other makes of hinged pipe cutters.

5090	1/2"-2" pipe capacity.....	6 lbs. (3kg)
95041	2 1/2"-4" pipe capacity	14 lbs. (6kg)
95061	4"-6" pipe capacity.....	22 lbs. (10kg)
95081	6"-8" pipe capacity	28 lbs. (13kg)
95121	8"-12" pipe capacity.....	39 lbs. (18kg)

Replacement Cutter Wheels:

8039	for 5090 for steel
8050	for 95041 for steel
8052	for 95061 for steel
8054	for 95081, 95121 for steel
8051	for 95041 for CI/DI
8053	for 95061, 95081, 95121 for CI/DI
8076	for 95061, 95081, 95121 / universal wheel



PIPE CLEANER (Descaler)

A versatile scraper for removing mud and scale from pipe surfaces. Makes for faster cutting and better repairs and joints. Belt material is light, strong and non-corroding. Angled blades promote self-cleaning. Belt is replaceable, longer length reduces back strain.

1300	For 3-12" diameter, 45" OAL.....	4 lbs. (2kg)
1301	Replacement Belt, 45".....	3 lbs. (1.5kg)
1350	For 12-36" diameter, 72" OAL.....	5 lbs. (2.5kg)
1351	Replacement Belt, 72".....	4 lbs. (2kg)

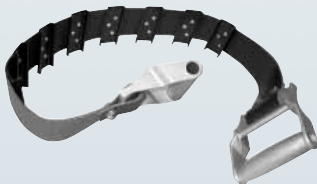

PIPE CUTTERS

CONTINUED



See this pipe cutter in action on our website at www.wheelerrex.com



Tripod Pipe Support sold separately

2500 KWIKSNAP

A semi-auto production cutter for cast iron soil pipe from the company who invented the "squeeze and pop" principle. Cuts 1 1/2"-6" soil pipe fast, easy and safely. Much cleaner than chop saws. Electric/hydraulic power is quiet and reliable. Built in handle and pneumatic tires for easy transport.

Gross weight, packed375 lbs. (171kg)
 Net weight258 lbs. (118kg)

Features:

- Five second cutting cycle time
- Unique chain design eliminates resetting for each cut on same size
- Semi-auto operation
- Much cleaner than sawing
- Dual pressure switches for safety

Specifications:

- Dimensions 32" x 20" x 50"
- 10" pneumatic wheels
- 1 hp. electric motor, 11.2 amps, 115V, 60Hz

5222 Replacement Cutter Chain5 lbs. (2.3kg)



In two minutes of cutting time:

Compare!!

Chop Saw	Conventional Cutter	KwikSnap 2500



2525 KWIKSNAP TABLE

A modular table design that quickly attaches to the 2500 KwikSnap. Simply drill holes in the KwikSnap cabinet to attach. Even with the tables attached, you will still have full access to all maintenance doors. Additional table section assemblies and leg/coupling assemblies can easily be added to either side of the KwikSnap.

2525 KwikSnap Table250 lbs. (114kg)

Assembly consists of three (3) 3' long table sections with removable rollers (a total of 9 linear feet), two (2) table leg assemblies, two (2) coupling brackets, two (2) machine to table brackets, four (4) table-leg coupling brackets, two (2) flipper assemblies and one (1) fence assembly. The fence assembly is easy to install and adjust with two quick action levers that fit into T-slots in the table top. Dimensions are 3' long x 16" wide x 30" tall when fitted to the leg assembly. Table legs have holes to anchor legs to floor as well as leveling bolts with jam nuts to eliminate the need for any shimming to level table.

The KwikSnap doors and top can be opened without removing the KwikSnap Table.



2526 Table Section Assembly.....55 lbs. (25kg)

The table assembly consists of one (1) 3' long x 16" wide x 4" tall table section complete with roller coupling brackets and fasteners, ready to attach to your existing 2525 table. (No leg or leg couplings are included.)

2527 Leg and Coupling Assembly37 lbs. (17kg)

Consists of leg with leg couplings.



Table Top with Fence



Flipper Assembly



Leg Adjustment

PIPE CUTTERS

CONTINUED



Blade cover removed for photographic purposes.

THE PIPEMASTER

General Information:

Unit consists of a cutting head with internal gears which operate the drive wheels and blade shaft. Cutting blades (except for No. 4616) must be cooled with water during cutting and are fully enclosed for safety. The cutter is held onto the pipe by a wide roller chain which is tensioned with a threaded take-up mechanism. A chart is included which tells the operator how much chain is required for various sizes of pipe. PipeMaster comes standard with cutting head, roller chain, wedges and water supply tank in a wood case. Blades are chosen based on pipe material and are not included with the basic machine. Maximum wall thickness for cutting is 1". The unit has a hydraulic motor which requires an external hydraulic power source. See our Model 6500 Power Pak and 701185 Bypass Valve on the next page.

- 4624 PipeMaster 6" to 24" (150-600mm)Shipping weight 99 lbs. (45kg)
- 4648 PipeMaster 6" to 48" (150-1200mm) Shipping weight 112 lbs. (51kg)

PipeMaster Features:

- Maximum hydraulic requirements 6 gpm/1500 psi
- Gearbox: Worm Drive with 80-90W gear oil required
- Cutting speed: 3" (150mm) of surface travel per minute
1" (25mm) of diameter per minute
- Cutting Clearance: Radial 8" (200mm); Axial 16" (400mm)
- Blade Speed: 1200 RPM
- Construction: Aluminum gearbox, side plated steel; bronze gears, steel roller chain, drive wheels are aluminum with urethane covering

Cutting 30" pipe and larger may require special instructions to complete the cut.

PIPEMASTER BLADES

Three blades for Cast Iron, Ductile Iron and Steel Pipes. Available with diamond or carbide tipped. These blades will fit the Wheeler-Rex PipeMaster as well as Universal and Utility Cutters from Reed Manufacturing, Keel and WACHS.



Blade No. 4706
6" Carbide-tipped
Blade for Steel Pipe

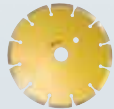

Blade No. 4606
6" Diamond Blade for
CI/DI Pipe



Blade No. 4616
6" Economy Diamond
Blade for DI Pipe

- 4706 6" Carbide Tipped Blade for steel pipes
- 4606 6" Diamond Blade for cast iron, ductile iron and clay pipes
- 4616 6" Economy Diamond Blade for ductile iron pipes. Cut dry or wet. Low price and excellent performance make this blade the best value on the market!!!



PipeMaster comes with these as standard accessories.

PIPEMASTER ACCESSORIES

- 700970 Drive Wheels for 6" pipe (2 required)
- 276693 Water Supply Tank, 4 gallon
- 700821 20' Hydraulic Hose Assembly complete with male/female FF quick disconnects
- 276288 Flat Face Male Quick Disconnect
- 276289 Flat Face Female Quick Disconnect
- 4686 Roller Chain, one link section
- 4685 Steel Wedge, set of 6 wedges
- 4606 6" Diameter Diamond Blade for CI, DI & clay
- 4706 6" Tungsten Carbide Tipped Blade for steel
- 4616 6" Economy Diamond Blade for DI pipe

Different drive wheels are required to cut 6" pipes (see part number 700970 above).

Number of Chain Links Required:

Pipe Diameter	24" (600mm)	48" (1200mm)
Number of Links	34 pieces	62 pieces



6500 HYDRAULIC POWER PAK 232 lbs. (105kg)

Features:

- Maximum hydraulic information: 6 gpm/1500 psi
- Adjustable pressure-relief valve
- Complete with 6.5 hp. Honda engine, on two-wheeled cart with pneumatic tires and cage
- Comes with two 700821 – 20' Hydraulic Hose Assemblies complete with male/female FF quick disconnects
- Can be used to power other hydraulic tools

701185 BYPASS VALVE KIT

Bypass Valve 6 gpm/1500 psi 10 lbs. (4.6kg)



Bypass Valve Kit is designed to be used with your truck, skid loader, backhoe or tractor's hydraulic system for use with the Wheeler Rex PipeMaster. The 701185 will adapt your current hydraulic system to the specs required to operate the PipeMaster (maximum 6 gpm/1500 psi). Weight is only 10 pounds and it is easy to connect. The PipeMaster's hydraulic lines will directly attach to the quick disconnects for both input and output points on the Bypass Valve. Hydraulic lines are required and are not included with the 701185 and are available as an additional accessory.*

*700821 20' Hydraulic Hose Assembly complete with male/female FF quick disconnects

Features:

- Maximum input from alternative hydraulic power source: 0–30 gpm/0–3000psi
- Maximum output from Bypass valve: 0–6 gpm/0–1500psi

GROOVING & FABRICATION



MANUAL ROLL GROOVER

Finger-adjust depth screw and gauge keys provide quick adjustment and accurate, repeatable grooves. The formed grooves comply with the specifications required for mechanical coupling systems.

6600 Forms standard roll grooves for 1 1/4"–6" steel pipe 20 lbs. (9kg)

Features:

- Lightweight at 20 lbs. for manual use
- 1 1/4"–6" Schedule 10 and Schedule 40 steel pipe
- 1 1/4"–6" Schedule 10 stainless steel pipe
- Can be used manually or in place when powered by Wheeler-Rex Model 7090, 8090, 6790 or 300 Machines
- Uses heavy duty bearings, hardened and ground shaft and roller
- Can roll groove 2"– 8" K, L, M & DWV copper pipe (with optional roller and shaft)
- Comes standard with bent ratchet and ratchet extension
- Grease fittings for lubrication points
- Ball detents on both depth screw and pinion gear



6601 Copper Manual Groover 24 lbs. (11kg)
 6602 Steel Roll Kit 4 lbs. (1.8kg)
 6603 Stabilizer Bars for Model 300 Machines 1 lbs. (.45kg)
 6604 Bracket Kit for 7090, 8090 & 6790 Wheeler-Rex Machines 6 lbs. (2.8kg)
 6605 Copper Roll Groove Kit 5 lbs. (2.3kg)

PORTABLE ROLL GROOVERS

For 1"–6" Schedule 5 to Schedule 40 steel. T-handle feed design minimizes operator fatigue. No separate ratchet required. SAFER – short lengths of pipe stay on rollers without operator assistance. All models are lightweight, compact and easily mounted. Carriage does not need to be removed for installation.

8400 2"– 6" Roll Groover with Base for 6090, 7090 & 8090 33 lbs. (15kg)
 8401 2"– 6" Roll Groover with Base for Model 300 33 lbs. (15kg)
 8402 2"– 6" Roll Groover with Base for Model 300 Compact 34 lbs. (15.5kg)
 8403 2"– 6" Roll Groover with Base for 6790 35 lbs. (15.9kg)

Accessories:

84000 Base Only for Models 6090, 7090 & 8090 Machines
 84001 Base Only for Model 300 Machines
 84002 Base Only for Model 300 Compact Machines
 84003 Base Only for Model 6790 Machines
 700628 2"– 6" Roller & Shaft Set for Copper Pipe
 700639 1" Roller & Shaft Set for Steel
 700640 1 1/4"–1 1/2" Roller & Shaft Set for Steel



HYDRAULIC ROLL GROOVER

For use with a pipe threading machine. Makes grooves 1"–16" Schedule 10 and 1"–12" Schedule 40. Conveniently and easily attaches to your 2" or 4" pipe threading machine. The carriage, reamer or die heads do not need to be removed from the machine. A simple mounting bracket provides quick attachment to Wheeler-Rex 6090, 7090, 8090 and 6790 Threading Machines as well as Model 300 Machines.

9700 Hydraulic Roll Groover with Base for Wheeler-Rex 6090, 7090 & 8090 79 lbs. (35.8kg)
 9701 Hydraulic Roll Groover with Base for Wheeler-Rex 6790 79 lbs. (35.8kg)
 9703 Hydraulic Roll Groover with Base for Model 300 Machines 79 lbs. (35.8kg)

Features:

- Compact, light weight, powerful and large capacity
- Built-in hydraulic cylinder
- Easy operation with guide roller to prevent the pipe from slipping and helps to eliminate vibration
- Unit comes standard with 2"– 6" Roller Set (341133) for Schedule 40
- Capacity: 1"– 16" Schedule 10 Steel (341125 Spacer)
 1"– 12" Schedule 40 Steel Pipe





9700 Hydraulic Roll Groover on Threader.

HYDRAULIC ROLL GROOVER ACCESSORIES

- 341560 Machine Mounting Kit for Wheeler-Rex 6090, 7090 & 8090
- 341562 Machine Mounting Kit for Wheeler-Rex 6790
- 341563 Machine Mounting Kit for Model 300 Machines
- 341118 Roller Set 1"–1½" Schedule 5–10 SUS 30–50 Su
- 341119 Roller Set 2"–3" Schedule 5–10 SUS 60–80 Su
- 341120 Roller Set 4"–6" Schedule 5–10 SUS 100–150 Su
- 606459 Roller Set 8" Schedule 40, 8"–12" Schedule 10
- 341137 Roller Set 10"–12" Schedule 40
- 341138 Roller Set 14"–16" Schedule 10
- 606460 Roller Set 1"–1½" Schedule 40
- 341141 Shaft 1"–1½"
- 341124 Spacer for 8"–12"

HYDRAULIC ROLL GROOVING MACHINES

Produces factory grooves on 1"–12" Schedule 10 and 1"–8" Schedule 40 steel pipe. Unique features include horizontal self-centering head, finished groove indicator light and optional electric power pump. Two (2) 220V outlets required; one (1) for the motor and one (1) for the hydraulic system. Standard rollers included for 2"–6".

Specifications: 220V 50–60Hz ONLY

Standard Accessories: 2"–6" rollers, toolbox and tools.

- 7702 2"–6" with manual pump
Gross weight, packed272 lbs. (124kg)
- 7703 2"–6" with electric power pump
Gross weight, packed272 lbs. (124kg)

Optional Accessories:

- 606520 2"–6" Roller Set
- 606459 8"–12" Roller Set
- 606460* 1"–1½" Roller Set
- 606461* 1"–1½" Roller Shaft

**Both items are required to groove 1"–1½" pipe*



ORBITAL PIPE CUTTER

For 4"–12" (100–300mm) steel and ductile iron pipe. The clamshell frame and modular design make this machine fast and easy to set up and operate. A single frame and gear plate make the orbital the most economical unit for its size range. Standard 115V electric power. Complete with all necessary accessories and packed in a storage case.

- 6412 Cut & Bevel, DI & CI pipe 4"–12" (100–300mm)
- 8412 Cut & Bevel, steel pipe 4"–12" (100–300mm)
- 5412 Cut & Groove, steel pipe 4"–12" (100–300mm)
- Gross weight271 lbs. (123kg)
- Net weight217 lbs. (98kg)

Spares and Accessories:

- 220267 Cut-Off Blade, DI
- 220808 RH Cut-Off Blade, steel
- 220809 LH Cut-Off Blade, steel
- 220705 30° Steel Bevel Blade
- 220706 37½° Steel Bevel Blade
- 220770 45° Steel Bevel Blade
- 220707 45° DI Bevel Blade
- 220855 Support Stand (not included with orbital as standard feature–purchased separately)



Support stand not included.

MANTIS™ BAND SAWS

A band saw with twice the action by quickly and easily changing the vise. Cuts pipes – even bundled pipes, square pipes, large pipes and many other types with ease. Can be locked in an upward position to use as a vertical table saw.

8415	Band Saw with Chain Vise	101 lbs.	(46kg)
8416	Band Saw with Flat Vise	115 lbs.	(53kg)
475190	Chain Vise Unit	13 lbs.	(6kg)
475192	Flat Vise Unit	27 lbs.	(13kg)

Specifications:

Motor:	120V, 50/60Hz 345W
Pulley Speed:	70 min-1 (50Hz) 80 min-1 (60Hz)
Blade Dimensions:	64.5" x .51" x .025"
Band Saw Dimensions:	35.4" x 14.2" x 16.6"

Features:

- Lightest weight band saw in its class
- Very easy to change the blade
- 1/4" – 6" cutting capacity
- Cuts steel, stainless steel, cast iron, conduit or polyethylene/polypropylene pipes
- Weight is counter-balanced for straight cuts
- Vises change quickly & easily with three bolts
- Great for cutting angles on square pipes
- Safety shut-off switch
- Can cut bundled pipes
- Cover is designed to store spare blades
- Comes standard with 14 tooth HSS blade
- Other blades available



8415



8416



Blade storage in cover.



Change from chain vise to flat vise quickly and easily!
Three bolts make the change!

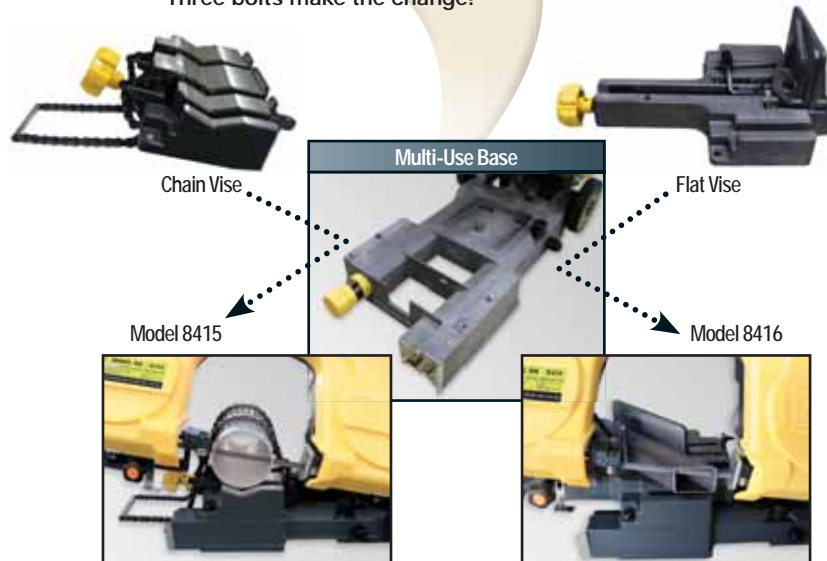



Cart available as an extra option.



You can even use the Mantis™ as a vertical band saw.

Large Pipes

Bundled Pipes

Cuts Angles

60504 Optional Cart53 lbs. (24kg)

MANTIS™ REPLACEMENT BLADES

Blade Number	Material	Number of Teeth
475200	Alloy	8
475201		10
475202		14
475203		18
475204		24
475210	High-Speed Steel Bimetal	10
475211		14
475212		18
475213		24
475220	Grid Saw	—

Blade Selection Table

Select blade and cutting load appropriate for type, diameter and wall thickness of material to be cut.

Material		LL= Ultra light load L= Light load M= Medium load H= Heavy load										
		Alloy					High-Speed Steel				Grid Saw	
		8	10	14	18	24	10	14	18	24		
Steel Pipe	1/4" - 1"			L	L			L	L			
	1 1/4" - 3"			M	M			M	M			
	3 1/2" - 6"			H	H			H	H			
Stainless Steel	Sch 40	1/4" - 1"						L	L			
		1 1/4" - 3"						M	M			
		3 1/2" - 6"							H	H		
Polyethylene or Polypropylene				LL	LL			LL	LL			
Conduit	Thick Steel				M				M			
	Thin Steel				L	L			L	L		
Cast Iron Pipe				H				H				
Cast Iron Cement											H	
Steel	Section Steel	≤ 5/64"					LL				LL	
		3/32" - 5/32"			L	L			L	L		
		5/32" - 3/16"			M	M			M	M		
		1/4" - 5/16"		M	H			M	H			
	≥ 5/16"		H	H			H	H				
	Round Bar	≤ 5/8"			M	M			M	M		
		5/8" - 2"			H				H			
2 1/32" - 3 1/4"		H	H				H	H				

THREADING EQUIPMENT



MANUAL RATCHET THREADER SETS

Wheeler-Rex Drop Heads and Dies are ideal for in-place threading from 1/2" - 2" and are designed to fit Wheeler Ratchet Handle 43310 as well as the Ridge Tool Company Models 12R, OO-R, 111-R, O-R, 30A & 31A, 600 & 700 Power Drives, Reed Mfg. DHR12 Series Drop Heads and Berkley Tool BT40000 Series Drop Heads.

4200	Complete with Tool Box for 1/2" - 2".....	49 lbs.	(22kg)
4202	Complete with Tool Box for 1/2" - 1".....	27 lbs.	(12kg)
4207	Complete with Tool Box for 1/2" - 1 1/4".....	31 lbs.	(14kg)
4209	Complete with Tool Box for 1/2" - 2" NPSM.....	49 lbs.	(22kg)
4211	Complete with Tool Box for 1" - 2".....	39 lbs.	(18kg)
4215	Complete with Tool Box for 1/2" - 2" BSPT.....	49 lbs.	(22kg)
4213	Complete without tool box for 1/2" - 2".....	35 lbs.	(16kg)
43310	Ratchet Handle.....	5.5 lbs.	(2.5kg)
43300	Replacement Carrying Case.....	14 lbs.	(6kg)



MINI POWER DRIVES

Lightweight and portable, the Wheeler-Rex Mini Power Drive can thread up to 2" diameter pipe or conduit and 1" bolt or rod in just seconds. Accepts 12R style die heads or 11R style with adapter. Requires only 1 3/4" clearance for working in trenches, overhead and in tight quarters and can tighten nuts, drive cable pullers, turn hoists and jacks, open and close valves. Mechanical high speed reverse speeds removal after threading.

640	Power Drive, 12R Adapter & Safety Vise with Case.....	38 lbs.	(17kg)
-----	---	---------	--------

Accessories:

6401	Case only for 640.....	13 lbs.	(6kg)
6402	12R Adapter for 640.....		

Safety Vise:

80115	Absorbs torque from Power Drives to reduce fatigue and protect the operator.....	6 lbs.	(3kg)
-------	--	--------	-------



64200 RATCHET THREADER KIT AND POWER DRIVE COMBO

Model 4200 Manual Ratchet Threader Set for 1/2" - 2" and the Model 640 Mini Power Drive ordered as one convenient kit, but each tool still includes their own tool box.

Gross weight.....	87 lbs.	(39kg)
-------------------	---------	--------



Mini Power Drive shown with Trisland and Safety Vise.

HAND OPERATED OILER

The Wheeler-Rex hand operated oiler features a metal reservoir bucket, removable plastic scrap/chip tray and 56" hose with trigger nozzle. Includes one gallon of ThreadMaster Oil.

5900	Shipping weight.....	16 lbs.	(7kg)
59050	Replacement Hand Pump.....		



12R STYLE REPLACEMENT DIES AND DIE HEADS

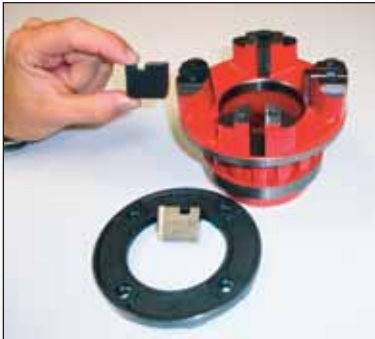

12R STYLE DIES - NPT

Wheeler #	Ridge #	Nominal Pipe Size	Type Thread	Die Material
837810	37810	1/8"	NPT	Alloy
837815	37815	1/4"	NPT	Alloy
837820	37820	3/8"	NPT	Alloy
837825	37825	1/2"	NPT	Alloy
837830	37830	3/4"	NPT	Alloy
837835	37835	1"	NPT	Alloy
837840	37840	1 1/4"	NPT	Alloy
837845	37845	1 1/2"	NPT	Alloy
837850	37850	2"	NPT	Alloy

12R STYLE DROP HEAD WITH DIES - NPT

Wheeler #	Ridge #	Nominal Pipe Size	Type Thread	Die Material
837375	37375	1/8"	NPT	Alloy
837380	37380	1/4"	NPT	Alloy
837385	37385	3/8"	NPT	Alloy
837390	37390	1/2"	NPT	Alloy
837395	37395	3/4"	NPT	Alloy
837400	37400	1"	NPT	Alloy
837405	37405	1 1/4"	NPT	Alloy
837410	37410	1 1/2"	NPT	Alloy
837415	37415	2"	NPT	Alloy

12R STYLE DIES - BSPT

Wheeler #	Ridge #	Nominal Pipe Size	Type Thread	Die Material
866110	66110	1/8"	BSPT	Alloy
866115	66115	1/4"	BSPT	Alloy
866120	66120	3/8"	BSPT	Alloy
866125	66125	1/2"	BSPT	Alloy
866130	66130	3/4"	BSPT	Alloy
866135	66135	1"	BSPT	Alloy
866140	66140	1 1/4"	BSPT	Alloy
866145	66145	1 1/2"	BSPT	Alloy
866150	66150	2"	BSPT	Alloy

12R STYLE DROP HEAD WITH DIES - BSPT

Wheeler #	Ridge #	Nominal Pipe Size	Type Thread	Die Material
865950	65950	1/8"	BSPT	Alloy
865955	65955	1/4"	BSPT	Alloy
865960	65960	3/8"	BSPT	Alloy
865965	65965	1/2"	BSPT	Alloy
865970	65970	3/4"	BSPT	Alloy
865975	65975	1"	BSPT	Alloy
865980	65980	1 1/4"	BSPT	Alloy
865985	65985	1 1/2"	BSPT	Alloy
865990	65990	2"	BSPT	Alloy

12R STYLE DIES - NPSM

Wheeler #	Ridge #	Nominal Pipe Size	Type Thread	Die Material
837945	37945	1/8"	NPSM	Alloy
837950	37950	1/4"	NPSM	Alloy
837955	37955	3/8"	NPSM	Alloy
837960	37960	1/2"	NPSM	Alloy
837965	37965	3/4"	NPSM	Alloy
837970	37970	1"	NPSM	Alloy
837975	37975	1 1/4"	NPSM	Alloy
837980	37980	1 1/2"	NPSM	Alloy
837985	37985	2"	NPSM	Alloy

12R STYLE DROP HEAD DIES - NPSM

Wheeler #	Ridge #	Nominal Pipe Size	Type Thread	Die Material
837555	37555	1/8"	NPSM	Alloy
837560	37560	1/4"	NPSM	Alloy
837565	37565	3/8"	NPSM	Alloy
837570	37570	1/2"	NPSM	Alloy
837575	37575	3/4"	NPSM	Alloy
837580	37580	1"	NPSM	Alloy
837585	37585	1 1/4"	NPSM	Alloy
837590	37590	1 1/2"	NPSM	Alloy
837595	37595	2"	NPSM	Alloy



PIPE THREADING MACHINES



7991 SIDEKICK II PIPE THREADER

The Wheeler-Rex Model 7991 is a full-featured threading machine for 1/4" to 1" pipe. Featuring front and rear chucks, an auto-open auto-oiling notch-type die head, safety auto shut-off, larger carriage & cutter handles and a unique one blade reamer.

Model 7991 Features:

- Auto open notch die head
- Front and rear chucks
- Auto-oiling die head
- Large scrap tray
- Weighs only 58 pounds
- Safety auto shut-off
- One blade reamer
- 1" pipe threading time — 16 seconds
- Built-in carrying handle
- Foot switch
- Spare cutter wheel.

Includes:

- 1/2"-1" die head
- Two sets of dies: 1/2"-3/4" and 1"

Specifications:

Standard Capacity: 1/2"-1"

Voltage: 115V

Motor: 400W series, single phase

Free Speed: 55 RPM

Net Weight: 58 lbs.

Dimensions: 15" x 11" x 12"

Optional:

- 1/4"-3/8" NPT dies
- 1/4"-1" NPT Die Head
- 841 Stand



Gross weight, packed..... 62 lbs. (28kg)
 Net weight..... 58 lbs. (26kg)

7992

Same as 7991 except comes complete with 60131 manual opening die head for 1/4"-1" and 1/2"-3/4" and 1" NPT dies.

Gross weight, packed..... 67 lbs. (31kg)
 Net weight, packed 63 lbs. (29kg)

7993

Same as 7991 except comes complete with two 1/2"-1" quick opening 70131 die heads and one each 1/2"-3/4" and 1" NPT dies.

Gross weight, packed..... 71 lbs. (32kg)
 Net weight, packed 66 lbs. (30kg)

7998

Same as 7991 except comes complete with 220V motor.

Gross weight, packed..... 62 lbs. (28kg)
 Net weight, packed 58 lbs. (26kg)

THREE YEAR WARRANTY, INCLUDING ELECTRIC MOTORS



Model 7991 shown on optional 841 Stand



Front and Rear Chucks



Notch-Type Auto Open Die Head — Oils thru the die head



Carriage and Cutter Handles are Larger

Unique One Blade Reamer





7890

Lightweight, easy to use, manual opening automatic oiling die head, compact and efficient. Completely equipped to cut, thread, and ream.

Features: For 1/2" to 1 1/2" pipe, 110V/120V, single phase 600W series motor, average noise level: 85db, maximum amperage under load: 12.2, no load RPM: 56

Includes: 1/4"-1 1/2" die head, two sets of NPT dies: 1/2"-3/4" and 1"-1 1/2", spare cutter wheel, foot switch, 3 legs.

Optional: 1/4"-3/8" NPT, 5/16"-1 1/2" UNC bolt, 1/2"-1 1/2" NPSM

Gross weight, packed 125 lbs. (57kg)

Net weight 105 lbs. (48kg)

THREE YEAR WARRANTY, INCLUDING ELECTRIC MOTORS.



8090

Features complete **interchangeability** with the Model 300 dies and die heads. This portable and compact, high-performance threading machine has a self-opening die head and through the die head oiling. Completely equipped to cut, thread and ream.

Features: For 1/2" to 2" pipe, 110/120V, single phase 700W series motor, average noise level: 85db, maximum amperage under load: 15.3, no load RPM: 39

Includes: 1/2"-2" die head, two sets of NPT dies: 1/2"-3/4" and 1"-2", spare cutter wheel, foot switch, 4 legs.

Gross weight, packed 153 lbs. (70kg)

Net weight 140 lbs. (64kg)

THREE YEAR WARRANTY, INCLUDING ELECTRIC MOTORS.

8096

Same as 8090 except comes with two 80118 Die Heads.

Gross weight, packed 158 lbs. (72kg)

Net weight 138 lbs. (63kg)

THREE YEAR WARRANTY, INCLUDING ELECTRIC MOTORS.



80118 Die Head

8097

Same as 8090 except comes with 897065 Universal Die Head for 1/8"-2".

Gross weight, packed 158 lbs. (72kg)

Net weight 138 lbs. (63kg)

THREE YEAR WARRANTY, INCLUDING ELECTRIC MOTORS.

8098

Same as 8090 except comes with 220V motor.

Gross weight, packed 175 lbs. (80kg)

Net weight 162 lbs. (74kg)

THREE YEAR WARRANTY, INCLUDING ELECTRIC MOTORS.

6090

Portable and compact, with self opening die head and through the die head oiling. Completely equipped to cut, thread, and ream.

Features: For 1/2" to 2" pipe, 110/120V, single phase 600W series motor, average noise level: 84db, maximum amperage under load: 18.5, no load RPM: 41

Includes: 1/2"-2" die head, two sets of NPT dies: 1/2"-3/4" and 1"-2", spare cutter wheel, foot switch, 3 legs.

Optional: 1/4"-3/8" NPT, 3/4"-2" beveling and grooving, 5/16"-2" UNC bolt, 1/2"-2" NPSM

Gross weight, packed 150 lbs. (69kg)

Net weight 130 lbs. (59kg)

THREE YEAR WARRANTY, INCLUDING ELECTRIC MOTORS.



PIPE THREADING MACHINES

CONTINUED



6790

The 6790 features a self-opening die head, with through die head oiling. Ultimate accuracy with quick changes between pipe sizes, producing quality threads. The 6790 offers adjustable thread length, three-stage oil filtration system, and a sturdy three flute reamer that covers the entire 1/2"-4" range. The 6790 is a three speed machine that is powered by a durable condenser motor, with an extremely low noise level. Completely equipped to cut, thread, and ream.

Features: For 1/2" to 4" pipe, 110V/120V or 220V/230V, single phase 1KW condenser motor, average noise level: 72db, maximum amperage under load: 18.5 no load RPM: 15/27/48

Includes: Two die heads: 1/2"-2" and 2 1/2"-4", three sets of NPT dies: 1/2"-3/4", 1"-2" and 2 1/2"-4", spare cutter wheel, foot switch, 4 legs and built-in tool tray.

Optional: 1/4"-3/8" NPT, 3/4"-4" beveling and grooving, 5/16"-2" UNC bolt, and 1/2"-4" NPSM
 Gross weight, packed 392 lbs. (178kg)
 Net weight 326 lbs. (148kg)

THREE YEAR WARRANTY, INCLUDING ELECTRIC MOTORS.

QUICK ADJUSTING NOTCH-TYPE DIE HEAD

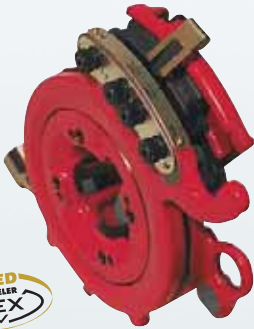

6793

Same as 6790 except with **THREE (3) self-opening NOTCH-TYPE DIE HEADS**. This offers accuracy, quick changes between pipe sizes and eliminates switching dies when changing pipe sizes. Completely equipped to cut, thread, and ream.

Gross weight, packed 416 lbs. (189kg)
 Net weight 344 lbs. (157kg)

THREE YEAR WARRANTY, INCLUDING ELECTRIC MOTORS.

6794

Same as 6790 except with a **BLADE-TYPE CUTTER**, which is designed for plastic lined pipe, as well as standard steel pipe. Completely equipped to cut, thread, and ream.

Features: For 1/2" to 4" pipe, 110V/120V or 220V/230V, single phase 1KW condenser motor, average noise level: 72db, maximum amperage under load: 18.5 no load RPM: 15/27/48

Includes: Two die heads: 1/2"-2" and 2 1/2"-4", three sets of NPT dies: 1/2"-3/4", 1"-2" and 2 1/2"-4", spare tray cutter wheel, foot switch, 4 legs and built-in tool tray.

Optional: 1/4"-3/8" NPT, 3/4"-4" beveling and grooving, 5/16"-2" UNC bolt, and 1/2"-4" NPSM
 Gross weight, packed 406 lbs. (185kg)
 Net weight 334 lbs. (152kg)

THREE YEAR WARRANTY, INCLUDING ELECTRIC MOTORS.



6590

This machine has self opening notch type die heads with through die head oiling. These die heads offer accuracy and quick changes between pipe sizes, while providing quality threads. The 6590 is totally gear driven and powered by a condenser motor, producing extremely low noise levels. Quiet operation permits use in hospitals, factories, and in other locations where noise can be a problem. Completely equipped to cut, thread, and ream.

Features: For 2 1/2" to 6" pipe, 110/120V or 220V/230V, single phase .75KW condenser motor, average noise level: 76db, maximum amperage under load: 14.5, no load RPM: 6.1/20.2

Includes: Two die heads: 2 1/2"-4" and 5"-6", two sets of NPT dies: 2 1/2"-4", and 5"-6", foot switch, 4 legs and Blade-Type Cutter.

Optional: 2 1/2"-6" beveling and grooving
 Gross weight, packed 523 lbs. (233kg)
 Net weight 451 lbs. (206kg)

THREE YEAR WARRANTY, INCLUDING ELECTRIC MOTORS.

THREADING ACCESSORIES & CUTTING FLUID



THREADER CARTS

60513	Collapsible Cart for Wheeler-Rex 8090 Pipe Threader	51 lbs.	(23kg)
60508	Collapsible Cart for Wheeler-Rex 7090 Pipe Threader	51 lbs.	(23kg)
60509	Collapsible Cart for Wheeler-Rex 6090 Pipe Threader	51 lbs.	(23kg)
60512	Collapsible Cart for 300 Style Pipe Threader	51 lbs.	(23kg)
60506	Threader Cart w/out Toolbox for 6390/6790/6794/6793.....	90 lbs.	(41kg)
60507	Threader Cart with Toolbox for 6390/6790/6794/6793.....	140 lbs.	(64kg)
60514	Threader Cart w/out Toolbox for 6590	90 lbs.	(41kg)
60515	Threader Cart with Toolbox for 6590.....	140 lbs.	(64kg)

NIPPLE ATTACHMENTS

87050	1/2" Nipple Chuck/Internal Pipe Wrench	5 oz.	(140g)
87075	3/4" Nipple Chuck/Internal Pipe Wrench	9 oz.	(252g)
87100	1" Nipple Chuck/Internal Pipe Wrench.....	10 oz.	(280g)
87101	Set of 3 Nipple Chucks (87050, 87075 & 87100)	24 oz.	(672g)
62000	1/2" NPT Nipple Chuck	3 lb.	(1.4kg)
62001	3/4" NPT Nipple Chuck	3 lb.	(1.4kg)
62002	1" NPT Nipple Chuck.....	3 lb.	(1.4kg)
62003	1 1/4" NPT Nipple Chuck.....	4 lb.	(1.8kg)
62004	1 1/2" NPT Nipple Chuck.....	4 lb.	(1.8kg)
62005	2" NPT Nipple Chuck.....	5 lb.	(2.3kg)
62006	2 1/2" NPT Nipple Chuck.....	7 lb.	(3.2kg)
62007	3" NPT Nipple Chuck.....	8 lb.	(3.6kg)
62009	4" NPT Nipple Chuck.....	11 lb.	(5kg)

841 PORTABLE THREADER STAND

Light weight folding stand. Designed to fit model 7991 Wheeler-Rex pipe Threading Machine	30 lbs.	(14kg)
---	---------	--------

WHEELER-REX PIPE THREADING OIL

Wheeler-Rex Pipe Threading Oil gives you premium performance at a reasonable price. Blended to thread Stainless Steel, Galvanized as well as Carbon Steel means you only need one oil for all your needs. Low odor and transparent appearance make this fluid pleasant to use in addition to creating quality threads and long die life.

60601	1 Gallon ThreadMaster Oil.....	8 lbs.	(3.5kg)
60604	1 Quart ThreadMaster Oil	2 lbs.	(.9kg)
60603	2 Quart ThreadMaster Oil	4 lbs.	(1.8kg)
60602	5 Gallon Pail of ThreadMaster Oil.....	42 lbs.	(19kg)
60655*	55 Gallon Drum of ThreadMaster Oil.....	434 lbs.	(197kg)

* Contact factory for current market price.

THREADING ACCESSORIES

CONTINUED



6990 PONY 1/4"-3/4" MAXIMUM PIPE RANGE

PART NO.	DIES
60210	1/4" - 3/8" NPT (60131 Die Head)
60211•	1/2" - 3/4" NPT (60130 Die Head)
DIE HEADS	
60130•	1/2" - 3/4" NPT/Self Opening Notch Style
SPARE PARTS	
60322•	Cutter Wheel
600979	Chuck Jaw Insert Set
602005	Motor Brush Set
602029	Reamer Cone

- Included with basic machine.

6991 SIDEKICK 1/4"-1" MAXIMUM PIPE RANGE



PART NO.	DIES
60210	1/4" - 3/8" NPT (60131 Die Head)
60211•	1/2" - 3/4" NPT (60130 & 60131 Die Heads)
60212•	1" NPT (60131 Die Head)
60256	1/2" - 3/4" NPSM (60131 Die Head)
60257	1" NPSM (60131 Die Head)
DIE HEADS	
60131•	1/4" - 1" NPT/Manual Opening
SPARE PARTS	
60322•	Cutter Wheel
602103	Chuck Jaw Insert Set
602005	Motor Brush Set
602125	Reamer Cone

- Included with basic machine.

7991 SIDEKICK II 1/4"-1" MAXIMUM PIPE RANGE



PART NO.	DIES
60210	1/4" - 3/8" NPT Dies (60131 Die Head)
60211•	1/2" - 3/4" NPT Dies (60130, 60131 & 70131 Die Heads)
60212•	1" NPT Dies (60131 & 70131 Die Heads)
60213	1/4" - 3/8" NPT Dies for S.S. (60131 Die Head)
60214	1/2" - 3/4" NPT Dies for S.S. (60131 & 70131 Die Heads)
60215	1" NPT Dies for S.S. (60131 & 70131 Die Heads)
60256	1/2" - 3/4" NPSM Dies (60131 & 70131 Die Heads)
60257	1" NPSM Dies (60131 & 70131 Die Heads)
DIE HEADS	
70131•	1/2" - 1" NPT/Quick Opening Die Head
60131	1/4" - 1" NPT/Manual Opening Die Head
SPARE PARTS	
60322•	Cutter Wheel
602103	Chuck Jaw Insert Set
606665	Motor Brush Set
606705	Reamer Blade

- Included with basic machine.

Model 6890 was discontinued 11/1/06 and these parts are interchangeable with Model 7890.

7890 1/4"-1 1/2" MAXIMUM PIPE RANGE



PART NO.	DIES
60200	1/4" - 3/8" NPT (60120 Die Head)
60201•	1/2" - 3/4" NPT (60120 Die Head)
60202•	1" - 1 1/2" NPT (60120 Die Head)
60346	5/16" - 18 UNC Bolt (60125 Die Head)
60347	3/8" - 16 UNC Bolt (60125 Die Head)
60348	7/16" - 14 UNC Bolt (60125 Die Head)
60340	1/2" - 13 UNC Bolt (60125 Die Head)
60341	5/8" - 11 UNC Bolt (60125 Die Head)
60342	3/4" - 10 UNC Bolt (60125 Die Head)
60343	7/8" - 9 UNC Bolt (60125 Die Head)
60344	1" - 8 UNC Bolt (60125 Die Head)
60345	1 1/8" - 1 1/4" 7 UNC Bolt (60125 Die Head)
60349	1 1/2" - 6 UNC Bolt (60125 Die Head)
DIE HEADS	
60120•	1/4" - 1 1/2" NPT/Manual Opening
60125	5/16" - 1 1/2" UNC Bolt/Manual Opening
SPARE PARTS	
60324•	Cutter Wheel
60323	Chuck Jaw Insert Set

7090 & 8090 1/8"-2" MAXIMUM PIPE RANGE



PART NO.	DIES
70201• #	1/2" - 3/4" NPT (70118, 80118 & 897065 Die Heads)
70209• #	1" - 2" NPT (70118, 80118 & 897065 Die Heads)
847735	1/8" NPT (897065 Die Head)
847740	1/4" - 3/8" NPT (897065 Die Head)
847745	1/2" - 3/4" NPT (70118, 80118 & 897065 Die Heads)
847750	1" - 2" NPT (70118, 80118 & 897065 Die Heads)
847775	1/8" S.S. (897065 Die Head)
847780	1/4" - 3/8" S.S. (897065 Die Head)
847785	1/2" - 3/4" S.S. (70118, 80118 & 897065 Die Heads)
847790	1" - 2" S.S. (70118, 80118 & 897065 Die Heads)
DIE HEADS	
70118•	1/2" - 2" NPT/Automatic Opening Die Head for 7090
80118#	1/2" - 2" NPT/Automatic Opening Die Head for 8090
897065	1/8" - 2" NPT/Quick Opening Die Head
SPARE PARTS	
60324• #	Cutter Wheel
70235	Chuck Jaw Insert Set
700715•	Oil Reservoir Plug
60508	Collapsible Threader Cart for 709051 lbs.
60513	Collapsible Threader Cart for 809051 lbs.

- Included with 7090 basic machine.
- # Included with 8090 basic machine.

6090 1/4"-2" MAXIMUM PIPE RANGE



PART NO.	DIES
60200	1/4" - 3/8" NPT (60115 Die Head)
60201•	1/2" - 3/4" NPT (60118 Die Head)
60209•	1" - 2" NPT (60118 Die Head)
60233	1/2" - 3/4" S.S. (60118 Die Head)
60238	1" - 2" S.S. (60118 Die Head)
60353	3/4" Beveling 37.5° (60117 Die Head)
60354	1" - 2" Beveling 37.5° (60117 Die Head)
60338	3/4" Grooving (60117 Die Head)
60339	1" - 2" Grooving (60117 Die Head)
60230	1/2" - 3/4" Conduit (60116 Die Head)
60231	1" - 1 1/4" Conduit (60116 Die Head)
60232	1 1/2" - 2" Conduit (60116 Die Head)
60346	5/16" - 18 UNC Bolt (60114 Die Head)
60347	3/8" - 16 UNC Bolt (60114 Die Head)
60348	7/16" - 14 UNC Bolt (60114 Die Head)
60340	1/2" - 13 UNC Bolt (60114 Die Head)
60341	5/8" - 11 UNC Bolt (60114 Die Head)

- Included with basic machine.

THREADING ACCESSORIES

CONTINUED



6090 CONTINUED

DIES (CONTINUED)	
60342	3/4" - 10 UNC Bolt (60114 Die Head)
60343	7/8" - 9 UNC Bolt (60114 Die Head)
60344	1" - 8 UNC Bolt (60114 Die Head)
60345	1 1/8" & 1 1/4" - 7 UNC Bolt (60114 Die Head)
60349	1 1/2" - 6 UNC Bolt (60114 Die Head)
60352	2" - 4 1/2" UNC Bolt (60114 Die Head)
DIE HEADS	
60115	1/4" - 2" NPT/Manual Opening
60118•	1/2" - 2" NPT/Automatic Opening
60114	5/16" - 2" UNC Bolt/Manual Opening
60117	3/4" - 2" Beveling & Grooving
60112	1/2" - 3/4" NPT/Automatic Opening, Notch type
60113	1" - 2" NPT/Automatic Opening, Notch type
60116	1/2" - 2" Conduit/Manual Opening
SPARE PARTS AND CART	
60324•	Cutter Wheel
60318	Chuck Jaw Insert Set
60328	Chuck Jaw Insert Set for Plastic Coated Pipe
60509	Collapsible Threader Cart 51 lbs.

6390 1/4"-2" MAXIMUM PIPE RANGE

PART NO.	DIES
60200	1/4" - 3/8" NPT (60115 Die Head)
60201•	1/2" - 3/4" NPT (60112 & 60115 Die Heads)
60233	1/2" - 3/4" S.S. (60112 & 60115 Die Heads)
60208•	1" - 2" NPT (60113 Die Head)
60234	1" - 2" S.S. (60113 Die Head)
60353	3/4" Beveling 37.5° (60117 Die Head)
60354	1" - 2" Beveling 37.5° (60117 Die Head)
60338	3/4" Grooving (60117 Die Head)
60339	1" - 2" Grooving (60117 Die Head)
60230	1/2" - 3/4" Conduit (60116 Die Head)
60231	1" - 1 1/4" Conduit (60116 Die Head)
60232	1 1/2" - 2" Conduit (60116 Die Head)
60346	5/16" - 18 UNC Bolt (60114 Die Head)
60347	3/8" - 16 UNC Bolt (60114 Die Head)
60348	7/16" - 14 UNC Bolt (60114 Die Head)
60340	1/2" - 13 UNC Bolt (60114 Die Head)
60341	5/8" - 11 UNC Bolt (60114 Die Head)
60342	3/4" - 10 UNC Bolt (60114 Die Head)
60343	7/8" - 9 UNC Bolt (60114 Die Head)
60344	1" - 8 UNC Bolt (60114 Die Head)
60345	1 1/8" & 1 1/4" - 7 UNC Bolt (60114 Die Head)
60349	1 1/2" - 6 UNC Bolt (60114 Die Head)
60352	2" - 4 1/2" UNC Bolt (60114 Die Head)
DIE HEADS	
60112•	1/2" - 3/4" NPT/Automatic Opening/Notch type
60113•	1" - 2" NPT/Automatic Opening/Notch type
60114	5/16" - 2" UNC Bolt/Manual Open
60115	1/4" - 2" NPT/Manual Opening
60117	3/4" - 2" Beveling & Grooving
60116	1/2" - 2" Conduit/Manual Opening
SPARE PARTS AND CART	
60324•	Cutter Wheel
60306	Chuck Jaw Insert Set
60506	Threader Cart NO Toolbox 90 lbs.
60507	Threader Cart with Toolbox 140 lbs.

- Included with basic machine.



6790, 6793 & 6794 1/4"-4" MAXIMUM PIPE RANGE



PART NO.	DIES
60200	1/4" - 3/8" NPT (60115 Die Head)
60201:•••	1/2" - 3/4" NPT (60112, 60115 & 60118 Die Heads)
60233	1/2" - 3/4" S.S. (60112, 60115 & 60118 Die Heads)
60209•••	1" - 2" NPT (60118 & 6 0115 Die Heads)
60208•••	1" - 2" NPT (60113 Die Head)
60234	1" - 2" S.S. Dies (60113 Die Head)
60238	1" - 2" S.S. (60118 & 60115 Die Heads)
60206:•••	2 1/2" - 4" Taper or Straight Threads (60106 Die Head)
60235	2 1/2" - 4" S.S. (60106 Die Head)
60353	3/4" Beveling 37.5° (60117 Die Head)
60354	1" - 2" Beveling 37.5° (60117 Die Head)
60330	2 1/2" - 4" Beveling 37.5° (60123 Die Head)
60332	2 1/2" - 4" S.S. Beveling 37.5° (60123 Die Head)
60338	3/4" Grooving (60117 Die Head)
60339	1" - 2" Grooving (60117 Die Head)
60227	2 1/2" - 3 1/2" Grooving (60123 Die Head)
60228	4" Grooving (60123 Die Head)
221066	2 1/2" - 3 1/2" Grooving Dies for S.S. (60123 Die Head)
221067	4" Grooving Dies for S.S. (60123 Die Head)
60346	5/16" - 18 UNC Bolt (60114 Die Head)
60347	3/8" - 16 UNC Bolt (60114 Die Head)
60348	7/16" - 14 UNC Bolt (60114 Die Head)
60340	1/2" - 13 UNC Bolt (60114 Die Head)
60341	5/8" - 11 UNC Bolt (60114 Die Head)
60342	3/4" - 10 UNC Bolt (60114 Die Head)
60343	7/8" - 9 UNC Bolt (60114 Die Head)
60344	1" - 8 UNC Bolt (60114 Die Head)
60345	1 1/8" - 1 1/4" - 7 UNC Bolt (60114 Die Head)
60349	1 1/2" - 6 UNC Bolt (60114 Die Head)
60352	2" - 4 1/2 UNC Bolt (60114 Die Head)
60230	1/2" - 3/4" Conduit (60116 Die Head)
60231	1" - 1 1/4" Conduit (60116 Die Head)
60232	1 1/2" - 2" Conduit (60116 Die Head)
DIE HEADS	
60115	1/4" - 2" NPT/Manual Opening
60118•••	1/2" - 2" NPT/Automatic Opening
60106:•••	2 1/2" - 4" Taper or Straight Threads/Automatic Opening/Notch Type
60117	3/4" - 2" Beveling & Grooving
60123	2 1/2" - 4" Beveling & Grooving
60112•••	1/2" - 3/4" NPT/Automatic Opening/Notch type
60113•••	1" - 2" NPT/Automatic Opening/Notch type
60114	5/16" - 2" UNC Bolt/Manual Opening
60116	1/2" - 2" Conduit/Manual Opening
SPARE PARTS AND CART	
60324:•••	Cutter Wheel
60310	Cutter Wheel
60301	HSS Cut-Off Blade
60390••	Cut-Off Blade for 6794
220204	HSS 10° Bevel Blade
60307	Chuck Jaw Insert Set
60327	Chuck Jaw Insert Set for Plastic Coated Pipe
60506	Threader Cart NO Toolbox 90 lbs.
60507	Threader Cart with Toolbox 140 lbs.
600282	Straight Profile Block Assembly for 2 1/2" - 4"
603680•••	Wheel Cutoff Assembly
600845••	Blade Cutoff Assembly

- Included with basic machine.
- Included with 6794 machine.
- Included with 6793 machine.

THREADING ACCESSORIES

CONTINUED

6590 2 1/2"-6" MAXIMUM PIPE RANGE



PART NO.	DIES
60206•	2 1/2"-4" Tapered or Straight (60127 Die Head)
60235	2 1/2"-4" NPT S.S. (60127 Die Head)
60207•	5"-6" Tapered or Straight (60128 Die Head)
60236	5"-6" NPT S.S. (60128 Die Head)
60330	2 1/2"-4" Beveling 37.5° (60121 Die Head)
60332	2 1/2"-4" S.S. Beveling 37.5° (60121 Die Head)
60331	5"-6" Beveling 37.5° (60122 Die Head)
60333	5"-6" S.S. Beveling 37.5° (60122 Die Head)
60227	2 1/2"-3 1/2" Grooving (60121 Die Head)
60228	4" Grooving (60121 Die Head)
221066	2 1/2"-3 1/2" Grooving Dies for S.S. (60121 Die Head)
221067	4" Grooving Dies for S.S. (60121 Die Head)
221068	5"-6" Grooving Dies for S.S. (60122 Die Head)
60229	5"-6" Grooving (60122 Die Head)
DIE HEADS	
60121	2 1/2"-4" Beveling & Grooving
60122	5"-6" Beveling & Grooving
60127•	2 1/2"-4" NPT Notch Style Tapered or Straight Automatic Opening
60128•	5"-6" NPT Notch Style Tapered or Straight Automatic Opening
ACCESSORIES	
60390•	Cut-Off Blade
60301	HSS Cut-Off Blade
220204	HSS 10° Bevel Blade
60310	Cutter Wheel
600280	Straight Profile Block Assembly
60514	Threader Cart NO Toolbox..... 90 lbs.
60515	Threader Cart with Toolbox..... 140 lbs.
60307	Chuck Jaw Insert Set
60327	Chuck Jaw Insert Set for Plastic Coated Pipe

- Included with basic machine.



7090 mounted on 60508 collapsible cart.



6790 mounted on 60507 cart.

UNIVERSAL REPLACEMENT DIES

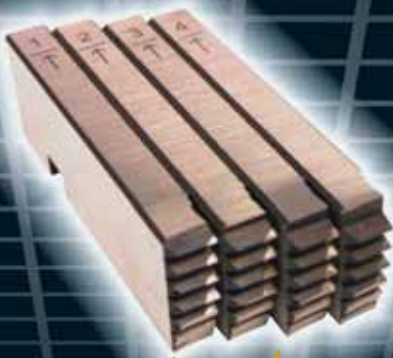

Ball Detents are Standard on all Wheeler-Rex Die Heads

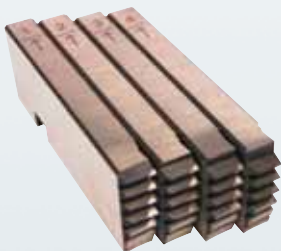

THREADING DIES

Wheeler-Rex Dies are manufactured from TOOL STEEL and are designed to fit Wheeler Die Head 897065 as well as the following Ridgid Tool Models 504A, 711, 713, 811A, 815A, 816, 817, and 842.

UNIVERSAL DIE HEAD

Wheeler # Ridge #
897065 97065 For 1/8"–2" Quick opening die head..... 13 lbs. (6kg)

PIPE DIES FOR UNIVERSAL DIE HEADS – NPT

Wheeler #	Ridge #	Nominal Pipe Size	Type Thread	Die Material
847735	47735	1/8"	NPT	Tool Steel
847740	47740	1/4"–3/8"	NPT	Tool Steel
847745	47745	1/2"–3/4"	NPT	Tool Steel
847750	47750	1"–2"	NPT	Tool Steel

PIPE DIES FOR UNIVERSAL DIE HEADS – NPT FOR STAINLESS STEEL

Wheeler #	Ridge #	Nominal Pipe Size	Type Thread	Die Material
847775	47775	1/8"	NPT	HSS
847780	47780	1/4"–3/8"	NPT	HSS
847785	47785	1/2"–3/4"	NPT	HSS
847790	47790	1"–2"	NPT	HSS

PIPE DIES FOR UNIVERSAL DIE HEADS – NPSM

Wheeler #	Ridge #	Nominal Pipe Size	Type Thread	Die Material
847825	47825	1/8"	NPSM	Tool Steel
847830	47830	1/4"–3/8"	NPSM	Tool Steel
847835	47835	1/2"–3/4"	NPSM	Tool Steel
847840	47840	1"–2"	NPSM	Tool Steel

BOLT DIES FOR UNIVERSAL DIE HEADS

Wheeler-Rex Bolt Dies are designed to fit Wheeler Die Head 897065 as well as the following Ridgid® Heads 504A, 711, 713, 811A, 815A, 816, 817 and 911.

Wheeler #	Ridge #	Nominal Pipe Size	Type Thread	Die Material
847985	47985	1/4"–20	UNC	Tool Steel
847990	47990	5/16"–18	UNC	Tool Steel
847995	47995	3/8"–16	UNC	Tool Steel
848000	48000	7/16"–14	UNC	Tool Steel
848005	48005	1/2"–13	UNC	Tool Steel
848010	48010	9/16"–12	UNC	Tool Steel
848015	48015	5/8"–11	UNC	Tool Steel
848020	48020	3/4"–10	UNC	Tool Steel
848025	48025	7/8"–9	UNC	Tool Steel
848030	48030	1"–8	UNC	Tool Steel
848035	48035	1 1/8"–7	UNC	Tool Steel
848040	48040	1 1/4"–7	UNC	Tool Steel
848045	48045	1 3/8"–6	UNC	Tool Steel
848050	48050	1 1/2"–6	UNC	Tool Steel
848055	48055	1 3/4"–5	UNC	Tool Steel
848060	48060	2"–4 1/2	UNC	Tool Steel

HYDROSTATIC TEST PUMPS



HAND OPERATED HYDROSTATIC TEST PUMPS

Ideal for testing residential water lines. Also for pressure testing small pressure tanks, sprinkler, boiler and solar systems. Lightweight and easy to use. $\frac{3}{4}$ " garden hose female inlet and $\frac{9}{16}$ "- 18 JICF male outlet. Equipped with shut-off valve, gauge, and adjustable internal relief valve. 10 foot output hose included.

29200	300 psi/21 bar (pictured), Shipping weight.....	12 lbs.	(5.5kg)
29201	1000 psi/70 bar, Shipping weight.....	12 lbs.	(5.5kg)

Accessories:

3915	10' High-Pressure Output Hose ($\frac{3}{8}$ " NPT male output connection)
29250	Pump Rebuild Kit
34550	10' Long Suction Hose with strainer ($\frac{3}{4}$ " male garden hose connection)

29900 HYDROSTATIC TEST PUMP

Designed especially for use in heating, compressed air, refrigeration systems, oil installations and sprinkler systems. Complete with 2.6 gallon stainless steel integral tank and 10 ft. output hose.

Specifications:	870 psi/60 bar, $\frac{1}{2}$ " connections
Shipping weight.....	17 lbs. (8kg)

Accessories:

3915	10' High-Pressure Output Hose
29950	Pump Repair Kit



GAS POWER OPERATED HYDROSTATIC TEST PUMPS

Ideal for certifying the integrity of newly installed or repaired water lines, sewer lines, commercial sprinkler systems, and pressure vessels. All gasoline driven models come with Briggs & Stratton™ Intek Pro or Honda engines and are backed by their warranties. Recirculating systems provide pump protection and water conservation. Carts are wheeled for ease of movement. All units come standard with 10 ft. high-pressure output hose and 10 ft. suction hose with strainer.



46301 ROLLER PUMP

Features: 5.4 gpm/300 psi (20.5 lpm/21 bar), 6.5 hp. B&S engine.
 Shipping weight.....132 lbs. (60kg)

463010 Same as 46301 except with 5.5 hp. Honda engine.....129 lbs. (59kg)
 36352 Pump Repair Kit for both Models



46453 TWIN PISTON PUMP

Features: 10 gpm/400 psi (38 lpm/28 bar), 6.5 hp. B&S engine.
 Shipping weight.....160 lbs. (73kg)

464530 Same as 46453 except with 5.5 hp. Honda engine.....160 lbs. (73kg)
 36351 Pump Repair Kit for both Models



36454 TWIN PISTON TEST PUMP

Features: 10 gpm/400 psi (38 lpm/28 bar), 6.5 hp. B&S engine. Comes complete with 10 ft. high pressure output hose and 10 ft. suction hose with strainer. Features roll cage instead of cart with wheels.
 Shipping weight.....135 lbs. (61.5kg)

364540 Same as 36454 except with 5.5 hp. Honda engine.....136 lbs. (62kg)
 36351 Pump Repair Kit for both Models



46200 TRIPLEX PLUNGER PUMP

Features: 3.5 gpm/1200 psi (13 lpm/84 bar), 6.5 hp. B&S engine.
 Shipping weight.....130 lbs. (59kg)

462000 Same as 46200 except with 5.5 hp. Honda engine.....130 lbs. (59kg)
 Accessories for Both Models:
 34052 Discharge Valve Kit
 34053 Pump Seal Kit



46501 TRIPLE DIAPHRAGM PUMP ...CAPABLE OF HANDLING 10% CHLORINE SOLUTIONS

Features: 10 gpm/500 psi (37.8 lpm/35 bar), 6.5 hp. B&S engine
 Shipping weight.....136 lbs. (62kg)

465010 Same as 46501 except with 5.5 hp. Honda engine.136 lbs. (62kg)
 36345 Pump Repair Kit for both Models
 36349 Pump Repair Kit for Models 46500 and 465000

Wheeled pumps are available with cages. Contact factory for details and pricing.

HYDROSTATIC TEST PUMPS

CONTINUED



46701 TRIPLE DIAPHRAGM PUMP WITH TANK

...CAPABLE OF HANDLING 10% CHLORINE SOLUTIONS

- 46701 Same as 46501 with pressure feed tank.....Shipping weights: 203 lbs. (92.5kg)
- 467010 Same as 465010 with pressure feed tank.....203 lbs. (92.5kg)
- 36345 Repair Kit for both Models
- 36349 Pump Repair Kit for Models 46700 and 467000



46600 DIAPHRAGM PUMP

...CAPABLE OF HANDLING 10% CHLORINE SOLUTIONS

- Features: 15 gpm/300 psi (57 lpm/21 bar), 6.5 hp. B&S engine
- Shipping weight.....136 lbs. (62kg)

- 466000 Same as 46600 except with 5.5 hp. Honda engine.....136 lbs. (62kg)
- 36347 Pump Repair Kit for both Models



46800 DIAPHRAGM PUMP

...CAPABLE OF HANDLING 10% CHLORINE SOLUTIONS

- Features: 26 gpm/250 psi (90 lpm/17.5 bar), 8 hp. B&S engine
- Shipping weight.....230 lbs. (104.5kg)

- 468000 Same as 46800 except with 8 hp. Honda engine.....233 lbs. (106kg)
- 36390 Pump Repair Kit for both Models

ELECTRIC POWERED HYDROSTATIC TEST PUMPS

The following units come standard with a 10 ft. high-pressure output hose.



39300 ELECTRIC HYDROSTATIC TEST PUMP

The ideal pump for certifying fire sprinkler lines, as well as commercial plumbing and industrial testing. Compact and lightweight for portability, yet powerful and rugged for professional use. Built-in adjustable pressure regulator.

- Features: 4 gpm/300 psi (15 lpm/20 bar) 1/2 hp., 115/230V, 60Hz Motor.
- Shipping weight.....35 lbs. (16kg)
- 39350 Pump Repair Kit

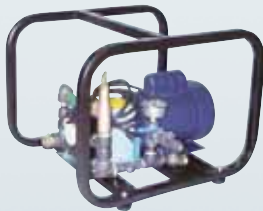

35100 TWIN PISTON PUMP

- Features: 3 gpm/500 psi (11 lpm/35 bar) 1 hp. capacitor start motor, 115/230V, single phase, 60Hz.
- Shipping weight.....91 lbs. (41.5kg)
- 36361 Pump Repair Kit

35101 TWIN PISTON PUMP

- Features: 3 gpm/500 psi (11 lpm/35 bar) 1 hp. capacitor start motor, 220V, single phase, 50Hz.
- Shipping weight.....91 lbs. (41.5kg)
- 36361 Pump Repair Kit



33100 TRIPLEX PLUNGER PUMP

- Features: 1 gpm/1000 psi (7 lpm/70 bar) 1 hp. capacitor start motor, 115/230V, single phase, 60Hz.
- Shipping weight.....87 lbs. (39.5kg)
- 36389 Pump Repair Kit

33101 TRIPLEX PLUNGER PUMP

- Features: 1 gpm/1000 psi (7 lpm/70 bar) 1 hp. capacitor start motor, 220V, single phase, 50Hz.
- Shipping weight.....87 lbs. (39.5kg)
- 36389 Pump Repair Kit



ELECTRIC DIRECT DRIVE TRIPLEX PLUNGER PUMPS

Features: single phase 1.5 hp., 15 amp. capacitor start motor

47100	2.2 gpm/1000 psi (10 lpm/70 bar) 115V, 60Hz	96 lbs.	(44kg)
47101	2.2 gpm/1000 psi (10 lpm/70 bar) 220V, 50Hz	96 lbs.	(44kg)
47102	1.1 gpm/2000 psi (5 lpm/138 bar) 115V, 60Hz	96 lbs.	(44kg)
47105	1.1 gpm/2000 psi (5 lpm/138 bar) 220V, 50Hz	96 lbs.	(44kg)

Accessories:

- 34052 Discharge Valve Kit
- 34053 Pump Seal Kit



37204 ELECTRIC DIRECT COUPLED TRIPLEX PLUNGER PUMP

Features: On 2-wheeled cart with full perimeter cage, 3.5 gpm/3000 psi (13.25 lpm/200 bar), 7.5 hp., 208/230V, 3-phase, 60Hz motor

Shipping weight.....225 lbs. (102.5kg)

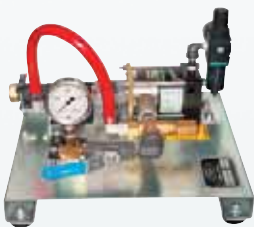

PNEUMATIC HYDROSTATIC TEST PUMP

32150 PNEUMATIC PUMP

Features: 1 gpm/1500 psi (3.8 lpm/105 bar), 100 psi @ 75 cfm required. (Not on wheeled cart)

Shipping weight.....34 lbs. (11kg)

32300 Same as 32150 except .5 gpm/3000 psi (1.91 lpm/206 bar) 100 psi @ 75 cfm required.....34 lbs. (11kg)



FIRE HOSE TESTERS

Quickly and safely tests fire hoses.

363020 3 gpm/500 psi, (10 lpm/35 bar), 115V, single-phase, 1 hp. capacitor motor, one (1) 1 1/2" NST swivel female quick fill inlet and two (2) 1 1/2" NST male outlets with individual ball valves. Cage mounted on swivel casters. Inlet and outlet hoses not provided.

Shipping weight.....128 lbs. (58kg)



363040 3 gpm/500 psi, (10 lpm/35 bar), 115V, single-phase, 1 hp. capacitor motor, one (1) 1 1/2" NST swivel female quick fill inlet and four (4) 1 1/2" NST male outlets with individual ball valves. Cage mounted on swivel casters. Inlet and outlet hoses not provided.

Shipping weight.....145 lbs. (66kg)



700536 VACUUM TEST ASSEMBLY

An easy way to check a trash pump for proper suction. Verify proper operation before putting a pump into service. Simply prime pump, place flat face over suction port and start pump

1 lb. (.45kg)

TRASH PUMPS



TRASH PUMPS

Specifically designed pumps for heavy duty applications. Handles solids with ease and simple to open and clean. Standard roll cage protects pump and engine. Steel strainer for intake hose included. Available with either Briggs & Stratton Intek™ Pro or Honda engines.

56200 2" TRASH PUMPS

- Features: 2" suction/discharge ports, 180 gpm/680 lpm, max solids up to 1",
6.5 hp. B & S engine.89 lbs. (41kg)
56201 Same as 56200 but with wheeled cart104 lbs. (47kg)

- 562000** Same as 56200 except with 5.5 hp. Honda engine.89 lbs. (41kg)
562001 Same as 562000 but with wheeled cart104 lbs. (47kg)

Accessories:

- 56250 2"x20' Suction Hose
56251 2"x25' Discharge Hose
56252 2" Cam Style Quick Connector Set
276270 Pump Repair Kit



56300 3" TRASH PUMPS

- Features: 3" suction/discharge ports, 300 gpm/1140 lpm, max solids up to
1.25", 6.5 hp. B & S engine.98 lbs. (46kg)
56301 Same as 56300 but with wheeled cart113 lbs. (52kg)

- 563000** Same as 56300 except with 5.5 hp. Honda engine.98 lbs. (46kg)
563001 Same as 563000 but with wheeled cart113 lbs. (52kg)

Accessories:

- 56350 3"x15' Suction Hose
56351 3"x25' Discharge Hose
56353 3" Cam Style Quick Connector Set
276271 Pump Repair Kit



56310 3" MUDSUCKER DIAPHRAGM-STYLE TRASH PUMP

- Features: 6.5 hp. B & S engine 3" female suction/discharge ports, 90 gpm / 340 lpm,
capable of pumping mud, slurry, sewage, thick liquids
and max solids up to 1 5/8".203 lbs. (93kg)

563100 3" MUDSUCKER DIAPHRAGM-STYLE TRASH PUMP

- Features: Same as 56310 except with 5.5 hp. Honda engine.....203 lbs. (93kg)

Accessories:

- 56350 3"x15' Suction Hose
56351 3"x25' Discharge Hose



4" ENGINE DRIVEN TRASH PUMP

Designed for applications which require high flow and solids handling capability. Constructed of heavy duty sand cast components with removable/replaceable cast iron volutes, impellers and wearplates. Easy front cleanout without disconnecting the hoses.

- 56400 13 hp. B & S Vanguard engine214 lbs. (97kg)
564000 13 hp. Honda OHV engine214 lbs. (97kg)

Features:

- 4" suction/discharge ports
- 540 gpm/44 psi
- Up to 2" maximum solids handling
- Low oil alert on engine
- Self priming up to 20 feet

Accessories:

- 56451 4"x15' Suction Hose
56452 4"x25' Discharge Hose
56354 4" Cam Style Quick Connector Set



Diesel engines
available –
Special request

Other sizes available upon request.

TUBE TOOLS



AUTO - C TUBING CUTTERS

With it's C-shape, these cutters are easy to grip and do not require any swing space. Just turn the cutter in the direction of the arrow and the cut will be complete in seconds. The spring loaded cutter wheel self feeds with consistent pressure. Cuts type-K, L and M copper and CTS CPVC.

5690	Auto-C Cutter 1/2" (15.9mm).....	5 lb.	(.23kg)
5691	Auto-C Cutter 3/4" (22.2mm).....	5 lb.	(.23kg)
5692	Auto-C Cutter 1" (28.6mm).....	5 lb.	(.23kg)
8046	Replacement Cutter Wheel		

4991 CLOSE QUARTERS TUBING CUTTER

Designed for plumbing remodeling, commercial boiler and air conditioning jobs, where standard cutters simply don't have the room. Cuts thin-wall material like traps and tailpieces with no distortion. Good for under vanities, close to walls, waste and overflows. Eliminates sawing which can loosen joints. One cutter wheel (No. 8038) cuts both plastic and non-ferrous materials. For 1/4" to 2 3/8" (6-59mm) O.D. non-ferrous tube and plastic pipe and tube.

	Shipping weight.....	1.5 lbs.	(.7kg)
8038	Replacement Cutter Wheel		



450 COPPER TUBE CLEANER

Cleans inside and outside 1/2" and 3/4" copper tubing. Leaves copper surface polished and cleaned for optimum solder flow. Replaceable high carbon steel bristles extend tool life beyond that of disposable brushes.

	Shipping weight.....	1 lb.	(.5kg)
No. 452:	Four Piece Replacement Brush Set		



4506 6-IN-1 COPPER TUBE CLEANER

Cleans inside and out plus deburrs the inside diameter of 1/2" and 3/4" tubing with hardened steel reamer/deburrer.

	Shipping weight.....	1 lb.	(.5kg)
No. 452:	Four Piece Replacement Brush Set		



TUBE TOOLS

CONTINUED

Wheeler-Rex offers a wide range of tube and pipe cutters for the professional. Many have innovative features that set them apart from other similar cutters.

RATCH CUT TUBE AND PIPE CUTTERS

3590 RATCH CUT WITH METAL HANDLE

Uniquely designed for fast, accurate pipe cutting, especially in confined, nearly inaccessible locations. Suitable for use on mild or stainless steel, copper or thinwall PVC and CPVC tubing from 1/8" to 3/8" (3-9mm).

Shipping weight..... .5 lbs.
8040 Replacement Cutter Wheel

3790 RATCH CUT WITH METAL HANDLE

A larger version of our Model 3590 cutter described above. Use it for quick, precise cutting of mild or stainless steel, copper or thinwall PVC and CPVC tubing from 5/16" to 1 1/8" (8-27mm).

Shipping weight..... 1.5 lbs.
8041 Replacement Cutter Wheel
8044 Cutter Wheel for thin walled stainless steel

4590 SELF-FEEDING RATCH CUT WITH METAL HANDLE

Uniquely designed for fast, accurate pipe cutting, especially in confined, nearly inaccessible locations. Simply place the cutter onto your pipe and begin ratcheting. The self-feeding cutter wheel will automatically tighten as you ratchet the handles back and forth. Suitable for use on 5/8" O.D. mild or stainless steel, copper or thinwall PVC and CPVC tubing.

Shipping weight..... 1.5 lbs.
8042 Replacement Cutter Wheel

4790 SELF-FEEDING RATCH CUT WITH METAL HANDLE

A larger version of our Model 4590 cutter described above. Use it for quick, precise cutting of 7/8" O.D. mild or stainless steel, copper or thinwall PVC and CPVC tubing.

Shipping weight..... 1.5 lbs.
8043 Replacement Cutter Wheel

700945 RATCH CUT KIT

Contains all four models of Ratch Cuts in a convenient carrying case.

Shipping weight..... 5 lbs.





MINI TUBING CUTTER

For accurate cutting of copper, brass, aluminum and stainless steel tubing.

- 90722 For 1/4" to 7/8" (6–22mm) O.D. 5 oz.
- 90728 For 1/8" to 1 1/8" (3–27mm) O.D. 10 oz.
- Replacement Cutter Wheel 8070 (for part no. 90722)
- 8071 (for part no. 90728)
- Replacement Cutter Wheel Pin Set 80716



TELESCOPIC TUBING CUTTER

For accurate cutting of copper, brass, aluminum and stainless steel tubing.

Telescopic cutter wheel feeding system keeps turning radius constant. Includes spare wheel. Swivel deburring tool retracts conveniently into the body.

- 90735 For 1/4" to 1 3/8" (6–35mm) O.D. 2 lbs.
- Replacement Cutter Wheel 8071
- Replacement Deburring Blade 80711
- Replacement Cutter Wheel Pin Set 80716



QUICK RELEASE TUBING CUTTER

Gives clean square cuts on copper, brass, aluminum tubing and thin walled conduit.

Changing the cutter wheel allows plastic pipe to be cut. Tool includes two cutter wheels and swivel deburring tool which is stored conveniently in the body of the cutter.

- 90750 For 1/4" to 2 5/8" (6–67mm) O.D. 2 lbs.
- Replacement Cutter Wheel 8071
- 8073 Plastic
- Replacement Deburring Blade 80711
- Complete Deburring Tool 80712
- Replacement Cutter Wheel Pin Set 80715



QUICK RELEASE TUBING CUTTER

Gives clean, square cuts on plastic and non-ferrous metal pipe. Spring loaded cutter wheel feeding system allows slide-action size adjustment and quick release.

- 90751 For 2" to 5" (50–127mm) O.D. 4 lbs.
- Replacement Cutter Wheel for plastic 8074 – standard
- Replacement Cutter Wheel for non-ferrous metals 8025 – optional
- 90752 For 4" to 6 5/8" (100–168mm) O.D. 4 lbs.
- Complete Burring Tool 80713
- Replacement Cutter Wheel for plastic 8075 – standard
- Replacement Cutter Wheel for non-ferrous metals 8025 – optional
- Cutter Wheel Pin Set 80718

TUBE TOOLS

CONTINUED



INNER & OUTER REAMER

For fast, clean, inner and outer reaming and outer deburring/beveling of 3/8" – 2" copper and stainless steel tubing. Made of hardened steel construction.

50100 Inner/Outer Reamer 3/8" – 2" (10mm–54mm) 1 lb. (.46kg)

DEBURRING TOOL

Ideal for removing internal burrs in copper, plastic, aluminum and steel tubing. Features long lasting replaceable high speed steel blade and plastic handle with built-in pocket clip.

920 Deburring Tool05 oz.

Replacement HSS Blade 80711

921 10 Pack of 920 Deburring Tools in Handy Hang-up Pack 6 oz.



4700 HAMMERHEAD FLARING TOOL

Four interchangeable heads flare 3/4" – 2" type-K copper pipe. The 6 lb. slide hammer is easier and safer than regular hammers and the pressure-relieving heads allow flaring with water in the line. Complete with custom carrying case.

Shipping weight 19 lbs. (9kg)



4900 REROUNDING TOOL KIT

Wheeler-Rex Rerounding Tools quickly and easily rereound soft type-K copper tubing for proper seal when using compression fittings. For safety, use only with brass hammers. For 3/4" through 2" copper pipe, compact, divided kit makes transport easy.

Shipping weight 12 lbs. (5.4kg)

49075 3/4" Rerounding Tool* 1.5 lbs. (.7kg)

49100 1" Rerounding Tool* 2.5 lbs. (1.14kg)

49150 1 1/2" Rerounding Tool* 3.5 lbs. (1.6kg)

49200 2" Rerounding Tool* 5.5 lbs. (2.5kg)

* Included in 4900 Tool Kit

4910 Brass Hammer 4.5 lbs. (2kg)



REPLACEMENT CUTTER WHEELS



PIPE CUTTERS

WHEELER REX NO.	WHEELER CUTTER NO.	RIDGID* NO.	RIDGID* CUTTER	REED** NO.	REED** CUTTER
8001	9590	F514 M-50 F3, F3S	1,2,42,535,300,50, 1A,2A,42A,201,202	2RBHD	2-1,2-1Q,2-4WG 2-3,2-3Q,2-4
8002		E1032	300,535,1822-1 MACH	HX2 1/2	H2 1/2
8004	4690 (SS)				
8006		F367	6S,208,209	R367	
8016	4690 (Steel)	F515	3S,4S,44S,466		
8039	5090				
8060	Ellis Style - CI				
8061	Ellis Style - S, DI				
8081	2690				
8082	2690				
700201	32900,42900				

TUBING CUTTERS- METAL

8012	9290/9291	E1240			TC2Q,T20,MC3
8015	9290/9291	F158	00,0,10,15,20		TC1Q,T10,TC15,T15
8021		E2191	30,40,106,107	30-40	TC3Q,TC4Q,TC5Q
8025	9490	E2558	154,156	30-40	TC6Q,TC8QP
8034		E3469	101,103-105,131,152	345T	MC2
8038	4990,4991				
8040	2590,3590				
8041	2790,3790				
8042	4590				
8043	4790				
8044	2790,3790				
8045		E4546	132,150-153,205	R45-46	MC2
8046	5690, 5691, 5692			03375	TC50SL,TC75SL,TC1SL
8070	90716,90722,90734				
8071	90735,90728,90750				

TUBING CUTTERS- PLASTIC

8037		E2156,E5299,E2157	30P,40P,133P,134P,136P 154P,156P,106,109P	3-6PVC	TC3Q,TC4Q,TC5Q TC6Q
8065			15,20	OP2	TC1Q,TC2Q,T10 T15,TC15,T20
8073	90750				
8074	90737,90751				
8075	90738,90752				

HINGED CUTTERS

8004		F229S	44,3S,4S,44S,466,468,472	3RG	
8050	95041			HS4	H4
8051	95041			HI4	H4
8052	95061			HS6	H6
8053	95061,95081,95121			HI6	H6,H8,H12
8054	95081,95121			HS8-12	H8,H12
8076	95061,95081,95121			H6PSE5	H6,H8,H12

THREADING MACHINES

60322	WHEELER REX MODELS 6990, 6991 & 7991				
60324	WHEELER REX MODELS 7890, 6090, 7090, 8090, 6190, 6290, 6390, 6490, 6790				
60390	CUTTER BLADE FOR 6794 & 6590				
60310	HSS CUTTER WHEEL FOR 6790, 6793, 6794 & 6590				
60301	HSS CUT-OFF BLADE FOR 6794 & 6590				

ROTATING PIPE CUTTERS

8838				RC18-30	ALL
8839				RCS8-30	ALL

* RIDGID IS A REGISTERED TRADEMARK OF THE RIDGE TOOL CO.

** REED IS A REGISTERED TRADEMARK OF THE REED MFG. CO.

GLASS TUBE CUTTERS



GLASS TUBE CUTTERS

For cutting glass tube and pipe as well as other brittle tubular materials. These tools are based on the original Wheeler "Squeeze and Pop" principle employing cutter wheels in the chain.



INVENTED BY: WHEELER REX

69012

For 1/4" thru 3/4" (6-18mm) O.D. gauge glass, laboratory glass, and porcelain tube. Small enough to carry in your pocket and almost as simple to use as a pair of pliers. Just wrap the chain around the tube, and hook the nearest chain pin in the jaw. Then a quick twist of the wrist, a slight squeeze of the handles, and pop!

Shipping weight..... 1 lb.



INVENTED BY: WHEELER REX

79014

For 1/4" thru 1" (6-25mm) O.D. gauge glass, laboratory glass, and porcelain tube. Small enough to carry in your pocket and almost as simple to use as a pair of pliers. Just wrap the chain around the tube and insert it through the jaw. Then a quick twist of the wrist, a slight squeeze on the handles, and pop!

Shipping weight..... 1 lb.



INVENTED BY: WHEELER REX

79022

For 1/4" thru 1 1/2" (6-37mm) O.D. gauge glass, laboratory glass, and porcelain tube. Similar to the model 79014 except with a longer chain. Small enough to carry in your pocket and simple to use. Just wrap the chain around the tube and insert it through the jaw. Then a quick twist of the wrist, a slight squeeze on the handles, and pop!

Shipping weight..... 1 lb.

REPLACEMENT GLASS CUTTER CHAIN

69012 GLASS CUTTER; 79014 GLASS CUTTER; 79022 GLASS CUTTER

Part No.	Description	Length	No. of Pins
690012	Complete Chain for 69012 Glass Cutter	3" (75mm)	12
7914	Complete Chain for 79014 Glass Cutter	5 1/2" (137mm)	14
7922	Complete Chain for 79022 Glass Cutter	8" (200mm)	22

PLASTIC PIPE TOOLS



PROFESSIONAL SNIPPERS

Wheeler-Rex Professional Snippers have been proven with years of professional use to be the snippers to have in your tool box. Durable and of high quality, with strong construction and long blade life, they are a must!

4190 MICRO SNIPPER

For 1/4" to 3/8" (6-9mm) O.D. soft plastic tubing and hose.

Weight..... .25 lb. (.12kg)

Great for PVC supply lines!

5190 SNIPPER

For 1/8" to 1 1/4" (3-31mm) O.D. soft plastic tubing and hose.

Weight..... .5 lb. (.25kg)

Replacement Blade No. 5200

Blades are reversible for double life. Handles are die-cast aluminum — NOT plastic.

5191 With Teflon® Coated Blade

For 1/8" to 1 1/4" (3-31mm) O.D. soft plastic tubing and hose, and 1/2" and 3/4" (12-19mm) 160 lb. and 200 lb. PVC.

Weight..... .5 lb. (.25kg)

Replacement Blade No. 5299

Blades are reversible for double life. Handles are die-cast aluminum — NOT plastic.

5290 RATCHET ACTION

For 1/8" to 1 5/8" O.D. (3-42mm) Schedule 40 Materials: PVC, ABS, vinyl, poly pipe and tubing. Ratchet style

Weight..... 1 lb. (.5kg)

Replacement Blade No. 5300

7290 RATCHET ACTION

For 1/8" to 2 7/16" O.D. (3-63mm) Schedule 40 Materials: Polyethylene, Polybutylene, Polypropylene, vinyl, PVC, and ABS pipe and tubing. Ratchet style. One hand operation.

Weight..... 2 1/2 lbs. (1.1kg)

Replacement Blade No. 7300

ECONOMY SNIPPERS

Need a snipper, but only for the occasional job? Wheeler-Rex has an economical way for you to do just that and not spend a lot of money!

5195 ECONOMY SNIPPER

For 1/8" to 1 1/4" O.D. (3-31mm) soft plastic tubing and hose.

Weight..... .51 lb. (.25kg)

Replacement Blade No. 5196

5295 ECONOMY RATCHET ACTION

For 1/8" to 1 5/8" O.D. (3-41mm) Schedule 40 Materials: PVC, ABS, vinyl, poly pipe and tubing. Easy to use, anti-rust, anti-wear construction with a heat treated blade.

Weight..... 1 lb. (.45kg)

Replacement Blade No. 5296

7325 BLADE SHARPENER

Quickly and easily restores the sharp edges on snipper blades. The Wheeler-Rex blade sharpener only requires 3 or 4 strokes to properly put that sharp edge back to your blade.

Weight..... 1.5 oz. (.04kg)

Works great on snipper blades, guillotine cutter blades and knives!!



PLASTIC PIPE TOOLS

CONTINUED

HAND SAWS

Two sizes with comfort fit handles: for plastic pipe and miscellaneous materials.
CUTS ON PUSH AND PULL STROKE.

- 600** 18" long blade (37mm).
Capacity: 1/2" to 6" (12-150mm) Sold in cartons of six or individually
- 601** With Teflon® coated blade: 18" long (37mm).
Capacity: 1/2" to 6" (12-150mm) Sold in cartons of six or individually
- 602** 13" long blade (25mm).
Capacity: 1/2" to 3" (12-75mm) Sold in cartons of six or individually
- 603** With Teflon® coated blade: 13" long (25mm).
Capacity: 1/2" to 3" (12-75mm) Sold in cartons of six or individually

Replacement Blades:

- 610** Replacement Blade for 600 Hand Saw sold in cartons of twelve or individually
Shipping weight for carton..... 6 lbs. (2.7kg)
- 611** Replacement Blade for 601 Hand Saw sold in cartons of twelve or individually
Shipping weight for carton..... 6 lbs. (2.7kg)
- 612** Replacement Blade for 602 Hand Saw sold in cartons of twelve or individually
Shipping weight for carton..... 4 lbs. (1.8kg)
- 613** Replacement Blade for 603 Hand Saw sold in cartons of twelve or individually
Shipping weight for carton..... 4 lbs. (1.8kg)

ECONOMY LARGE HAND SAW

Cuts PVC and ABS on push / pull stroke. With a 26" blade and comfort fit handle. Available with standard blade or Teflon® coated blade.

- 726** 26" Hand Saw3 lbs. (1.3kg)
- 730** 26" Hand Saw with Teflon® blade3 lbs. (1.3kg)

Replacement Blades:

- 727** Replacement Blade for 726 Hand Saw
- 731** Replacement Blade for 730 Hand Saw

PVC AND ABS CABLE SAW

Cut PVC and ABS in tight places where other methods will not work. Simply slip the cable saw around the pipe and see-saw to quickly make a cut. Available in two lengths.

- 626** 26" Cable Saw06lb.
- 636** 36" Cable Saw07lb.

9015 HAND OPERATED PLASTIC PIPE BEVELER

The Universal Plastic Pipe Beveler makes a 15° bevel on SDR35 and Sch 40 thermoplastic pipe through 12" (300mm) capacity. It is lightweight and easy to adjust to different wall thicknesses for beveling and deburring. **Wide saddle won't twist and dig into the pipe like others.**

- Capacity: 1 1/2" through 12" (38-300mm) Diameter
- Shipping weight.....7 lbs. (3kg)
- Replacement Bevel Blade No. 220083

POWER OPERATED PLASTIC PIPE BEVELER

The power bevelers are designed for a wide variety of situations including high production applications. Our advanced HSS cutter design makes a smooth 15° bevel, which is adjustable for length and depth. Tools are easy to use and drastically reduces beveling time, especially on large pipe sizes or when doing production beveling.

- 9000** Capacity: 4" (100mm) and up. 115V, 1 3/4 hp., 11.0 amp motor,
24,500 RPM.....14 lbs. (6.4kg)
- 9001** Model 9000 with Carbide Bit.....14 lbs. (6.4kg)
- 9050** Pneumatic Beveler 1 1/2 hp., 20,000 RPM.....12 lbs. (5.5kg)
- 220220** Beveler Unit less router
- 220234** Replacement HSS 15° Router Bit Assembly with 3/8" Shank
- 220041** Replacement Carbide 15° Router Bit Assembly with 3/8" Shank
- 220092** Replacement HSS 15° Router Bit Assembly with 1/2" Shank
- 220047** Replacement Carbide 15° Router Bit Assembly with 1/2" Shank



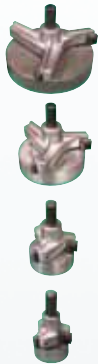

PIPE HOG® PVC / ABS FITTING REAMER

Quickly and accurately bores out solvent welded fittings to make repairs. Fits 1/2" drill chuck. Saves time and material. Pays for itself in one use.

16150	1 1/2" Pipe Hog for Schedule 40	9 oz.
16200	2" Pipe Hog for Schedule 40	12 oz.
16300	3" Pipe Hog for Schedule 40	1 lbs. 2 oz.
16400	4" Pipe Hog for Schedule 40	1 lbs. 8 oz.
16010	Pipe Hog Kit with extension shaft.....	8 lbs. 4 oz.

Accessories:

700588	Schedule 80 Guide for 16150
700589	Schedule 80 Guide for 16200
700590	Schedule 80 Guide for 16300
700591	Schedule 80 Guide for 16400
16050	12" Extension Shaft
16055	1/2" Square Carbide Insert

Pat. No. 3,752,593



FITTING SAVER

Quickly and easily removes pipe from solvent welded fittings. Fits 3/8" drill chuck. Saves time and money over replacing whole assemblies. Perfect for plumbing, irrigation and sprinkler contractors.

Fitting Savers for Schedule 40

17050	1/2" IPS Fitting Saver25 lbs.
17075	3/4" IPS Fitting Saver35 lbs.
17100	1" IPS Fitting Saver50 lbs.
17010	Sch 40 Fitting Saver Kit (contains 17050, 17075, 17100 Fitting Savers in case).....	1.6 lbs.

Fitting Savers for Schedule 80

17051	1/2" IPS Fitting Saver25 lbs.
17076	3/4" IPS Fitting Saver35 lbs.
17101	1" IPS Fitting Saver50 lbs.
17020	Sch 80 Fitting Saver Kit (contains 17051, 17076, 17101 Fitting Savers in case).....	1.6 lbs.
18050	1/2" CTS Fitting Saver.....	.15 lbs.
18075	3/4" CTS Fitting Saver.....	.20 lbs.

BEFORE

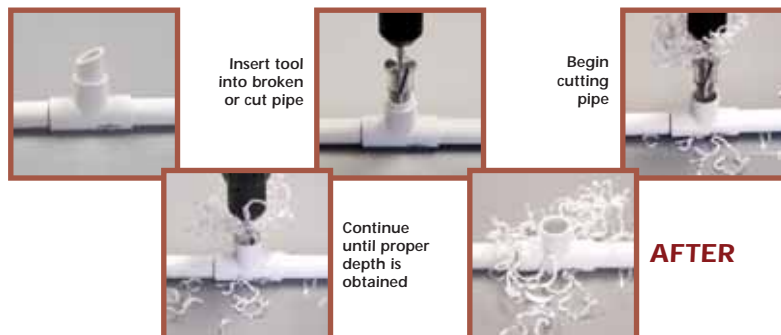

AFTER

PLASTIC PIPE TOOLS

CONTINUED

INTERNAL PLASTIC PIPE CUTTERS

Make accurate, square cuts at floor level or in other blind locations. Cutters are easily preset for depth of cut and make their cuts in seconds. Recommended user supplied power source: 1/2" capacity, 350–450 RPM drill, rated at 4.6 to 6 amps.

For PVC and ABS plastic pipe. For individual pipe sizes from 1 1/2" to 6" Diameter.



1590	For 1 1/2" Schedule 40 pipe and DWV.	Shipping weight	1 lb.
2290	For 2" Schedule 40 pipe and DWV.	Shipping weight	1 lb. 10 oz.
2492	For 2" Schedule 80 pipe and DWV.	Shipping weight	1 lb. 5 oz.
3290	For 3" Schedule 40 pipe and DWV.	Shipping weight	2 1/2 lbs.
3490	For 3" Schedule 80 pipe and DWV.	Shipping weight	2 1/2 lbs.
4290	For 4" Schedule 40 pipe and DWV.	Shipping weight	3 lbs.
4490	For 4" Schedule 80 pipe and DWV.	Shipping weight	3 lbs.
6000	For 6" Schedule 40 pipe and DWV.	Shipping weight	2 lbs. 11oz.

Replacement Blades:

1293	Replacement Blade for Models 1590, 2290 and 2492
3293	Replacement Blade for Models 3290 and 3490
4293	Replacement Blade for Models 4290, 4490 and 6000
700777	6' Drive Shaft for 1 1/2" – 2" models
700778	6' Drive Shaft for 3", 4" and 6" models

Model Number	Adjustable Cutting Depth Range
1590 & 2290	1 5/8" – 8 1/4"
3290 & 3490	1 5/8" – 8 1/4"
4290 & 4490	1 5/8" – 11 5/8"
6000	2 3/8" – 12 3/4"

POLY PIPE CHAMFERING TOOL / DEPTH GAUGE

Lightly bevels the end of polyethylene pipe prior to socket fusion. The tool is sized to allow marking for the proper end distance for the cold ring per ASTM F1056.



10050	1/2" CTS.....	2.3 oz.
10075	3/4" CTS.....	2.7 oz.
10100	1" CTS.....	3.4 oz.
10125	1 1/4" CTS.....	4.2 oz.
10150	1 1/2" CTS.....	5.5 oz.
10200	2" CTS.....	10 oz.
30050	1/2" IPS.....	2.6 oz.
30075	3/4" IPS.....	3.8 oz.
30100	1" IPS.....	3.6 oz.
30125	1 1/4" IPS.....	4.4 oz.
30150	1 1/2" IPS.....	5.4 oz.
30200	2" IPS.....	7.3 oz.
40020	20mm.....	2.5 oz.
40025	25mm.....	3.5 oz.
40032	32mm.....	3.4 oz.
40040	40mm.....	3.7 oz.
40050	50mm.....	4.5 oz.
40063	63mm.....	7.2 oz.
700155	Replacement Blade for All Models	

GUILLOTINE PIPE CUTTERS

892

Designed to cut medium and high-density polyethylene pipe up to 4.0" (125mm) O.D. Comes standard with removable T-Handle design, which can be removed to expose a 1" Hex nut. This nut can also be driven with a ratchet and 1" socket.

Shipping weight.....	17 lbs.	(8kg)
Replacement V-Shaped Blade 7011492 lbs.	(.9kg)
Replacement Straight Blade 7006922 lbs.	(.9kg)
Ratchet 6515		
Socket 506032		

1694

Designed to cut medium and high-density polyethylene pipe up to 8.0" (225mm) O.D. Comes standard with removable T-Handle design, which can be removed to expose a 1" Hex nut. This nut can also be driven with a ratchet and 1" socket.

Shipping weight.....	40 lbs.	(18kg)
Replacement V-Shaped Blade 7008682 lbs.	(.9kg)
Replacement Straight Blade 7004682 lbs.	(.9kg)
Ratchet 6515		
Socket 506032		

1890

A unique approach to cutting large diameter medium and high-density polyethylene pipes. Can be used with a low speed power drive (300–500 RPM maximum), that delivers power to the blade through a right angle worm drive. Power cutting at 300 RPM is a fast 1 minute per inch of pipe diameter and gives better cuts and longer blade life due to reduced flexing. Maximum cutting capacity of 13.2" (335mm) O.D. **Power source is not included.**

Shipping weight	80 lbs.	(36kg)
Replacement V-Shaped Blade 7010732 lbs.	(.9kg)
Replacement Straight Blade 7005142 lbs.	(.9kg)

1892

Designed to cut medium and high-density polyethylene pipe up to 14.2" (360mm) O.D. Comes standard with removable T-Handle design, which can be removed to expose a 1" Hex nut. This nut can also be driven with a ratchet and 1" socket.

Shipping weight.....	73 lbs.	(33kg)
Replacement V-Shaped Blade 7010732 lbs.	(.9kg)
Replacement Straight Blade 7005142 lbs.	(.9kg)
Ratchet 6515		
Socket 506032		

All models come standard with V-shaped Blade. Straight Blade Optional.

Guillotine Style Pipe Cutter Features:

- Medium and high density PE pipe cutting capacity
- Teflon® coated steel cutter blade creates outstanding ease of cutting and corrosion protection
- Wide saddle side-swing opening design simplifies positioning at any point on pipe
- Wide saddle base provides sturdy, positive pipe support
- Stainless steel fasteners and hardware
- Structural members produced from aircraft-grade aluminum
- Dry-lube coated drive screw



Ratchet
(optional)

Power Driven
(1890 only)

T-Handle
(standard with 892, 1692 & 1892)



PIPE WORKING TOOLS



4160 WHEELER-REX TRIPOD VISE STAND

For 1/8"– 6" pipe capacity. Lightweight and portable with a large top working area. It features a built-in chain vise, pipe bending slots, pipe rest, ceiling brace screw and hardened replaceable jaws. The lower tray folds for extra convenience.

Shipping weight.....53 lbs. (24kg.)



FOLDING TRIPOD PIPE SUPPORTS

Tripod Pipe Supports are designed to hold stock for threading machines, chop saws, and other equipment. Sturdy, all steel construction supports hold up to one ton (2000 lbs.) of materials: pipe, tubing, conduit, bar, rod, or structural steel. Quick-release locking ring allows for fast height adjustments, while 1 1/2" diameter Acme threads on the adjusting column provide fine height adjustments. Heavy duty lockscrew maintains height safely.

Height range is 27" to 50" (675–1250mm). Capacity: 1/2" to 16" (12–400mm) Diameter.

850 With standard V-head, Shipping weight.....28 lbs. (13kg)

851 With heavy duty ball transfer head, Shipping weight32 lbs. (14.5kg)

854 Ball Transfer Head only for use on standard V-head



850 Shown Collapsed





YOKE VISES

These vises firmly hold pipe and round bar stock for cutting, drilling, and threading operations. Vises are reversible for left or right opening. All jaws are made of hardened steel and can easily be replaced in the field. The yoke and base are constructed of high-grade malleable iron. Meets all Federal Specifications: GGG-V-415a Type 1, Class II.

Product Number	O.D. Capacity	Weight
13020	3/8" – 2 3/8" (60mm)	8 lbs. (3.5kg)
13040	3/8" – 3 1/2" (89mm)	11 lbs. (5kg)
13060	3/8" – 4 1/2" (114mm)	18 lbs. (8kg)
13080	3/8" – 5" (127mm)	27 lbs. (12kg)



FLOOR MODEL PIPE VISES

Wheeler-Rex Pipe Vises are designed to be portable and quickly assembled for field use, yet strong and tough enough for the shop. All models have a 2000 lb. (900kg) capacity. The quick releasing chain provides positive gripping power evenly around the pipe and prevents damage to pipe surfaces. Adjustments are fast to accommodate different pipe sizes.

- 400600 Capacity: 3/4" to 6" (18–150mm)
Shipping weight51 lbs. (23.2kg)
- 401500 Capacity: 3/4" to 15" (18–375mm)
Shipping weight54 lbs. (24.6kg)
- 402000 Capacity: 3/4" to 20" (18–500mm)
Shipping weight55 lbs. (25kg)
- 402800 Capacity: 3/4" to 28" (18–700mm)
Shipping weight56 lbs. (25.5kg)



PIPE PULLER

For joining all types of gasketed pipe: plastic, cast iron, clay, and concrete. Comes with two 12 ft. long anchor chains. Also pulls fittings, valves, and couplings into place. Lightweight yet rugged, this tool operates on a basic lever action and is used easily by one man.

- 4012 Pipe Capacity: 4 to 14" (100–350mm) Diameter
Shipping weight34 lbs. (15.5kg)

PLUG POPPER

Quickly and easily removes stubborn plugs from sewer pipes. No more struggling with plugs using screwdrivers or spades or breaking expensive plugs in order to get them out!! Made from steel for durability.

- 4060 6" Plug Popper5 lbs. (2.5kg)
- 4080 8" Plug Popper6 lbs. (3kg)



PIPE DOLLY

These dollies are used to support, rotate and align pipes. They are extremely heavy duty with 1" (25mm) diameter axle shafts. All steel construction. Normally used in pairs.

- 880 Capacity: 3" to 30" (75–750mm) pipe, 2500 lb. load rating each
Shipping weight23 lbs. (10.5kg)



SHUT-OFF TOOLS





SHUT-OFF TOOLS FOR SOFT COPPER PIPE

Our shut-off tools are invaluable for maintenance and installation of soft copper service lines where they can shut off, hold, and restore flow quickly and easily. They are handy for quick repairs with their swing-out design. Complete with socket, ratchet, holding clamp, and carrying case.

New & Improved — with Grease Fitting



- | | |
|---|--|
| 

 | <p>85 Capacity: 3/4" (20mm) through 1" (25mm) soft copper tubing
Includes: Ratchet, carrying case and #62 clamp.
Shipping weight 12 lbs. (5.5kg)</p> <p>86 Capacity: 1/2" (12mm) through 1" (25mm) soft copper tubing
Includes: Ratchet, carrying case and #62 clamp.
Shipping weight 13 lbs. (5.9kg)</p> <p>70 Capacity: 1 1/4" (31mm) through 2" (50mm) soft copper tubing
Includes: Ratchet, carrying case and #72 clamp.
Shipping weight 18 lbs. (8.2kg)</p> <p>8570 Combination of Models 85 and 70
Includes: ratchet, carrying case and clamps.
Shipping weight 25 lbs. (11.4kg)</p> <p>8670 Combination of Models 86 and 70
Includes: ratchet, carrying case and clamps.
Shipping weight 26 lbs. (11.8kg)</p> |
|---|--|

Accessories:

- | | |
|--|---|
| 
 | <p>62 1/2" (12mm) through 1" (25mm) Clamp for soft copper pipe</p> <p>72 1 1/4" (31mm) through 2" (50mm) Clamp for soft copper pipe</p> <p>6515 1/2" Square Male Drive Ratchet</p> <p>221220 Conversion Kit from 85 to 86</p> <p>506032 1" x 1/2" Square Drive Socket</p> |
|--|---|

SHUT-OFF TOOLS FOR PLASTIC PIPE

These unique portable valves shut off the flow of either water or gas in Polyethylene or Polybutylene plastic pipe. They are especially handy for fast on-the-spot repairs. Complete with socket, ratchet, and carrying case.

- | | |
|--|--|
| 
 | <p>75 Capacity: 3/8" to 2" (10-50mm) plastic water pipe.
Includes: ratchet and carrying case.
Shipping weight 14 lbs. (6.4kg)</p> <p>77 With adjustable stops to prevent damage to pipe.
Capacity: 3/8" to 2" (10-50mm) Plastic gas pipe.
Includes: ratchet and carrying case.
Shipping weight 15 lbs. (6.8kg)</p> |
|--|--|

PIPE FREEZING KIT



REPLACEMENT CANISTERS

ARCTIC POLAR SYSTEM® PIPE FREEZING KIT

Designed specifically for the professional, Wheeler-Rex Pipe Freezing Kits will rapidly form an ice plug in static water lines eliminating the need to drain down a system to make a repair. Ice plugs will last 15 to 20 minutes and can be easily renewed.

Kit comes complete with jackets for double freezes. No tools are required to set up and complete a freeze. An easy-to-use scale is included to ensure economical operation. Packaged in a convenient carrying case.

Polar Spray is non-toxic, non-flammable and ozone friendly.

TWO CAN PIPE FREEZING KIT

- 1755 $\frac{3}{8}$ " - 2 $\frac{3}{8}$ " O.D. Kit includes the following:
 2 jackets each - 17550 for $\frac{3}{8}$ " - $\frac{1}{2}$ ", 17551 for $\frac{5}{8}$ " - $\frac{7}{8}$ ", 17552 for 1" - 1 $\frac{3}{8}$ ",
 17553 for 1 $\frac{5}{8}$ ", 17554 for 2" - 2 $\frac{3}{8}$ ", valve, scale, t-fitting and 5' tubing.
 Shipping weight11.5 lbs. (5.3kg)
- 17500 Polar Spray Replacement Canister *per can*2 lbs. (.9kg)
 (Available in cases of 12 or individually)



Wheeler's Pipe Freeze Kits install in seconds on pipes up to 2 $\frac{3}{8}$ " O.D. and require no special tools. Ice plugs last 15-20 minutes and can be easily renewed.

DRILLING AND TAPPING TOOLS

HOT TAPPING SYSTEM

Capacity: from 3/4" to 2" (19-50mm) in Steel, Cast Iron, Ductile, and Plastic Pipe. The Wheeler-Rex Hot Tapping System is hand operated and designed for drilling holes in active water lines up to 250 psi. It is lightweight and easy for one man to set up and use. Complete with 6515 ratchet, tool box, adapters and cutter shells for making 3/4" (19mm) and 1" (25mm) holes. Adapters and cutter shells for over 1" do not come with standard kits and must be purchased separately.

Shipping weight (all models)26 lbs. (11.8kg)

- 8100 With 3/4" and 1" (19-25mm) HSS cutters and adapters to fit NPT threads.
- 8200 With 3/4" and 1" (19-25mm) HSS cutters and adapters to fit flared (CTS) ends.
- 8300 With 3/4" and 1" (19-25mm) HSS cutters and adapters to fit BSPT threads.

Built-in bleed-off valve allows chips to be flushed away.

ADAPTERS FOR NPT THREAD Model 8100

Wheeler Part No.	Description
802051+	3/4" NPT Adapter
802053+	1" NPT Adapter
802055	1 1/4" NPT Adapter
802057	1 1/2" NPT Adapter
802059	2" NPT Adapter

ADAPTERS FOR CTS FLARE Model 8200

802050*	3/4" CTS Flare Adapter
802052*	1" CTS Flare Adapter
802054	1 1/4" CTS Flare Adapter
802056	1 1/2" CTS Flare Adapter
802058	2" CTS Flare Adapter

ADAPTERS FOR BSPT THREADS Model 8300

802071•	3/4" BSPT Adapter
802072•	1" BSPT Adapter
802073	1 1/4" BSPT Adapter
802074	1 1/2" BSPT Adapter
802075	2" BSPT Adapter

ADAPTERS FOR MUELLER 110 CORP STOPS

802060	1 1/2" Adapter
802061	2" Adapter

CUTTER SHELLS FOR STEEL AND COPPER

903071*+•	3/4" HSS Shell Cutter
903072*+•	1" HSS Shell Cutter
903073	1 1/4" HSS Shell Cutter
903074#	1 1/2" HSS Shell Cutter
903075#	2" HSS Shell Cutter

CUTTER SHELLS FOR DUCTILE AND CAST IRON PIPE

904065	3/4" Carbide Tip Shell Cutter
904066	1" Carbide Tip Shell Cutter
904067	1 1/4" Carbide Tip Shell Cutter
904068	1 1/2" Carbide Tip Shell Cutter
904069	2" Carbide Tip Shell Cutter

CUTTER SHELLS FOR PLASTIC

5800	3/4" Shell Cutter for C-900 Plastic
5801	1" Shell Cutter for C-900 Plastic
802084	1 1/2" Shell Cutter for C-900 Plastic
802085	2" Shell Cutter for C-900 Plastic

ADDITIONAL ACCESSORIES

6515	1/2" Square Male Drive Ratchet
908097#	Threaded Adapter for HSS Shells (comes standard with 1 1/2" & 2" Cutter Shells)
908094	Center Drill

+Included with 8100 System *Included with 8200 System •Included with 8300 System #Adapter included with Cutter Shell

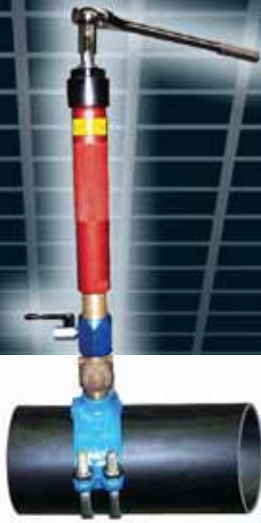

New!

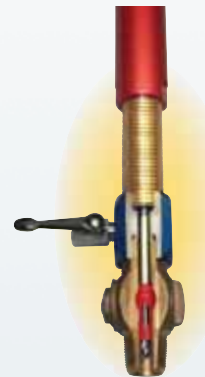

Cutaway View



COMBINED DRILL TAPS

Wheeler's combined drill taps bring you premium performance at a reasonable price. Designed and manufactured to produce a quality thread and ensure a pressure tight fit. Made from high speed steel, they are tough and durable and fit all popular tapping machines.

Wheeler-Rex Drill Taps will fit all popular tapping machines including:
 Mueller B100 • Mueller B101 • Mueller A2 • Mueller A3 • Hays Transmate B1 • All Reed

89075	3/4" CC Thread Drill Tap	19 oz.	(.54kg)
89100	1" CC Thread Drill Tap	21 oz.	(.6kg)
86075	3/4" CC PVC Drill Tap	16 oz.	(.45kg)
86100	1" CC PVC Drill Tap	24 oz.	(.68kg)

Resharpener service only available for Wheeler-Rex CC Thread Drill Taps (not available for PVC Drill Taps).

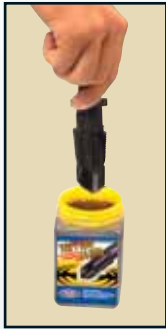

TAPPING FLUID

A completely new concept in a lubricant for drill taps and other related uses where a non-toxic food grade lubricant is required. Slik-tap is easy to apply, yet thick enough to hang onto the cutting tool, providing the lubrication to reduce tapping effort and produce clean threads.

8900	1 pint of Tapping Fluid Slik-Tap	1.5 lbs.
8901	12 pack of 8900 Tapping Fluid Slik-Tap	14 lbs. 9 oz.

PORTABLE HOLE CUTTER SYSTEM

A compact, light-weight hole cutter system that utilizes a drill to cut a hole in pipes. Designed to cut most materials, including steel.

Without drill – provide your own:

3090	With adaptor only for Milwaukee® Drill (less drill)	46 lbs.	(21kg)
3091	With adaptor only for DeWalt® DW130V Drill (less drill)	46 lbs.	(21kg)

With drill:

3092	Hole Cutter System with Milwaukee® Model 16606 Drill	57 lbs.	(26kg)
3093	Hole Cutter System with DeWalt® DW130V Drill	57 lbs.	(26kg)
701173	Drill Adapter Kit for DeWalt® 131 Drill for all models	1 lb.	(.5kg)

Features:

- Cuts holes up to 4 3/4" (120mm)
- Comes standard with metal carrying case
- For use with standard off-the-shelf hole saw (not included)
- Comes standard with enough chain for 10" pipes, extra chain available
- Handle can be changed for right or left feed
- Rack & pinion feed gear
- Fast, easy, secure mounting to pipe
- Spring loaded pin holds drill in position
- Comes complete and ready to use with either:
 DeWalt® DW130V Drill or Milwaukee® 1660-6 Drill



DRILLING AND TAPPING TOOLS CONTINUED



HOLE CUTTER SYSTEM

The Wheeler-Rex Hole Cutter System is designed to easily cut holes from 4" - 12" (100-300mm) into clay tile, ductile and cast iron, plastic and reinforced concrete pipes. The unit is available with a variety of power sources including 2-cycle gasoline engine, pneumatic motor, electric motor and hydraulic motor. The system is modular in design which allows a single operator to set up and perform non-pressure taps safely and quickly. The basic system can be used on pipes from 6" - 20" (150-500mm) O.D. and the capacity can be extended by simply adding chain to the hold down mechanism. Set up normally takes 5 - 10 minutes and actual cutting time is 5 - 10 minutes depending on pipe material and wall thickness.

- 1660 Complete with gasoline power pack and water valve assembly
Shipping weight (less cutter shells)..... 110 lbs. (50kg)
- 1661 Complete with air power pack and water valve assembly, 70-80 psi (4.6-5.5 bar),
50-60 cfm (1400-1700 lpm) Shipping weight (less cutter shells)..... 129 lbs. (59kg)
- 276582 Air Motor Repair Kit
- 1662 Complete with 115V electric motor and water valve assembly
Shipping weight (less cutter shells)..... 108 lbs. (49kg)
- 1663 Complete with hydraulic motor and water valve assembly, 8 gpm, 2000 psi
(30 lpm @ 130 bar) Shipping weight (less cutter shells)..... 110 lbs. (50kg)
Requires external hydraulic source. See page 11 for Model 6500 Hydraulic Power Pack
- 1664 Hole Cutter System less drive 93 lbs. (43kg)

701186 Bypass Valve for 1663 Hole Cutter System 8 gpm, 2000 psi..... 10 lbs. (4.6kg)

The Model 701186 is a Bypass Valve Kit designed to be used with your skid loader, backhoe or tractor for the Wheeler-Rex Model 1663 Hydraulic Hole Cutter System. The 701186 will adapt your current hydraulic system to the specs required to operate the 1663 Hole Cutter System. (8 gpm and 2000 psi required) Portable at 10 pounds and easy to connect. The hole cutter's hydraulic lines will directly attach to the quick disconnects for both input & output points on the bypass valve. Hydraulic lines not included (between hydraulic power source & bypass valve.)

- 210 HSS Center Drill for CI, DI & Plastic Pipe
- 211 Carbide-Tipped Center Drill for Clay and Concrete
- 220025 Coupon Retainer

HOLE CUTTER SHELLS

Nominal Hole Size	Clay Concrete	Reinforced Concrete, Clay, Ductile & Cast Iron	Plastic
4" (100mm)	3395*	6395*	4395
4 1/2" (112mm)	3450*	6450*	4450
6" (150mm)	3595*	6595*	4595
6 1/2" (172mm)	3650*	6650*	4650
8" (200mm)		6800*	4800

* Water coolant required

Larger sizes available upon request

EARTHWORM HYDRO-DRILL

Bores holes underground without trenching or disturbing surface materials. Ideal for installing water, gas, drain, and electrical lines. Comes standard with a combination drive/water valve assembly, and a 2" (50mm) diameter auger. User supplies 3/4" pipe for drill shaft.

- 7800 Shipping weight.....5 lbs. (3kg)

Additional Augers

- 7801 1" (25mm) Auger
- 7802 2" (50mm) Auger
- 7810 3" (75mm) Auger
- 7808 4" (100mm) Reversing Auger
- 7809 6" (150mm) Reversing Auger

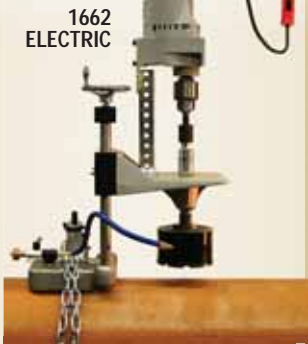

1662
ELECTRIC



1661
PNEUMATIC



1660
GAS



1663
HYDRAULIC



701186
Bypass Valve





Poly/Copper Pipe Pulling Attachments



Cable & Grip



Poly Pipe Pulling Attachments



Double Flare Tool



Copper Flare Locknut



Mini Pipe Slice

PIPE SLICES

8600 PIPE SLICE with 1" NPT Male Thread, 3 Blades3 lbs. (1.4kg)
Splits 3/4" to 2" poly pipe and copper or pulls out 3/4" – 2" lead or galvanized services.

Accessories:

8605	3/8" x 50' Cable with Ferrule.....	13 lbs.	(6kg)
8606	3/8" x 75' Cable with Ferrule.....	19 lbs.	(9kg)
8607	3/8" x 100' Cable with Ferrule.....	26 lbs.	(12kg)
8608	3/8" x 150' Cable with Ferrule.....	38 lbs.	(17kg)
8610	Cable Grip	9 lbs.	(4kg)
8625	3/4" Poly/Copper Pipe Pulling Attachment.....	1 lb.	(.5kg)
8626	1" Poly/Copper Pipe Pulling Attachment.....	1 lb.	(.5kg)

Kits:

8627	Includes 8600 Pipe Slice, 8605 50' Cable/Ferrule, 8610 Grip	24 lbs.	(10.9kg)
8628	Includes 8600 Pipe Slice, 8606 75' Cable/Ferrule, 8610 Grip	30 lbs.	(13.6kg)
8629	Includes 8600 Pipe Slice, 8607 100' Cable/Ferrule, 8610 Grip	36 lbs.	(16.4kg)
8630	Includes 8600 Pipe Slice, 8608 150' Cable/Ferrule, 8610 Grip	50 lbs.	(23kg)

8601 PIPE SLICE II with 1 1/2" – 12 Straight Thread, Single Blade..... 2.5 lbs. (1.2kg)
Splits 3/4" to 1" poly or copper pipe or pulls out 1" lead or galvanized services.

Accessories:

8605	3/8" x 50' Cable with Ferrule.....	13 lbs.	(6kg)
8606	3/8" x 75' Cable with Ferrule.....	19 lbs.	(9kg)
8607	3/8" x 100' Cable with Ferrule.....	26 lbs.	(12kg)
8608	3/8" x 150' Cable with Ferrule.....	38 lbs.	(17kg)
8610	Cable grip.....	9 lbs.	(4kg)
8645	3/4" PE Pipe Pulling Attachment.....	.70 lb.	(.32kg)
8646	1" PE Pipe Pulling Attachment.....	.81 lb.	(.37kg)
8648*	3/4" Copper Flare Locknut55 lb.	(.25kg)
8649*	1" Copper Flare Locknut45 lb.	(.21kg)
8647	3/4" and 1" Double Flare Tool52 lb.	(.24kg)

Kits:

8620	Includes 8601 Pipe Slice II, 8605 50' Cable/Ferrule, 8610 Grip.....	24.5 lbs.	(11kg)
8621	Includes 8601 Pipe Slice II, 8606 75' Cable/Ferrule, 8610 Grip.....	30.5 lbs.	(14kg)
8622	Includes 8601 Pipe Slice II, 8607 100' Cable/Ferrule, 8610 Grip.....	37.5 lbs.	(17kg)
8623	Includes 8601 Pipe Slice II, 8608 150' Cable/Ferrule, 8610 Grip.....	49.5 lbs.	(22.5kg)
8640	Includes 8601 Pipe Slice II, 8645 & 8646 PE Pulls, 8648 & 8649 Copper Locknut, 8647 Flare Tool.....	7 lbs.	(3.0kg)
8641	Includes 8601 Pipe Slice II, 8645 & 8646 PE Pulls	5 lbs.	(2.3kg)
8642	Includes 8601 Pipe Slice II, 8648 & 8649 Copper Locknut, 8647 Flare Tool.....	6 lbs.	(2.7kg)

*New Fittings for Copper Pipe:

Copper Connections: Simply slide the locking nut over the pipe, flare it and then slide the locking nut up and thread onto the back of the Pipe Slice II. The Pipe Slice II now has a radius at the back end to assist in securing the pipe to the tool.

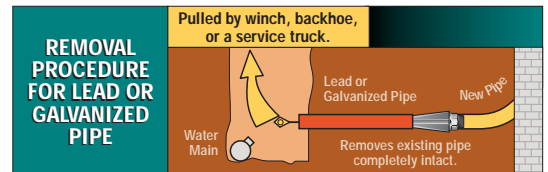
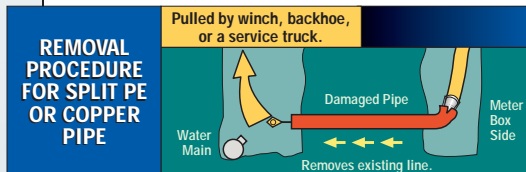

8500 MINI PIPE SLICE for 1/2" to 3/4" lines with 1/2" NPT Male Thread1 lb. (.5kg)

Accessories:

8506	1/4" x 50' Cable and Ferrule	6 lbs.	(2.7kg)
8507	1/4" x 75' Cable and Ferrule	9 lbs.	(4.1kg)
8508	1/4" x 100' Cable and Ferrule	12 lbs.	(5.4kg)
8525	1/2" – 3/4" Poly Pipe Pull Attachment	6 lbs.	(2.7kg)

Kits:

8520	Includes 8500 Mini Slice, 8506 50' Cable, 8610 Cable Grip	20 lbs.	(9kg)
8521	Includes 8500 Mini Slice, 8507 75' Cable, 8610 Cable Grip	25 lbs.	(12kg)
8522	Includes 8500 Mini Slice, 8508 100' Cable, 8610 Cable Grip	30 lbs.	(13.6kg)

Other cable lengths available upon request.

VALVE EXERCISERS



See the ValveMaster in action on our website at www.wheelerrex.com

INVENTED BY: WHEELER REX



Patent #5,810,051

Free CD Available!

98000 VALVEMASTER PORTABLE VALVE EXERCISER

ValveMaster portable valve exerciser delivers 0-600 ft. lbs. of torque with finger tip control. All torque absorbed by frame to protect the operator. Powered by 13 hp. B&S Vanguard engine (Honda Optional). Standard features include digital counter, 2" ball hitch coupling, 4.80 x 12" wheels and auxiliary connections for use as hydraulic power source for other tools.

(Type II 8 gpm, 2000 psi) 8ft telescoping key included550 lbs. (250kg)

98001 Same as 98000, except with Honda engine

98002 Same as 98000 with reversible counter

98003 Same as 98001 with reversible counter

Note: 8 foot is the maximum key length recommended for optimal performance.



68115



681150



681155



681150 in use

VALVE EXERCISER / POWER DRIVE

The 68 series valve exerciser offers high performance in a compact, lightweight package. A wide variety of adapters are available for multiple uses. 115V, 1/2 hp., 6 amps, 250 ft. lbs., 22 RPM.

68115 Power Drive only – For use with adapters below37 lbs. (17kg)
Other voltages may be available upon request.

681150 Power Drive with 1396444 lbs. (20kg)

681155 Rising Stem Valve Operator with counter and hand-wheel adapter
Shipping weight62 lbs. (28.1kg)

13964 Torque Limiting Adapter with counter and 1" square drive. 0-250 ft. lbs.
Shipping weight7 lbs. (3.2kg)

10709 1" Square Female Adapter
Shipping weight3 lbs. (1.4kg)

10696 Adapter for 12R drop head dies
Shipping weight3 lbs. (1.4kg)

701061 Electric Counter Assembly

13964

10709

10696

701061

New!



13968 RISING STEM TORQUE ADAPTER 9 lbs. (4kg)

Features:

- Clutch “slips” to keep operator and valve safe while exercising.
- Torque Specs: adjustable 0 – 200 ft/lbs.
- Unique clutch system allows you to set the torque accordingly, to exercise valves without exceeding their limit.
- Clutch can be easily adjusted with any 3/4" wrench. (Not included)
- Control Rods have graduations for approximate ft/lbs. of torque.
- To be used with the 13970 on rising stem valves.
- The 701061 counter assembly can be added to the 68115 and the 13970 for ease of valve revolution counting.
- Clutch is allowed to “slip” and keep correct count when using the 701061 counter assembly.

New!



13970 HAND-WHEEL ADAPTER 11 lbs. (5kg)

Features:

- Adapts to valves with hand wheels with or without rising stems up to 3" in diameter.
- Series of bolt holes to adapt to many different spoke patterns and styles available.
- Allows you to exercise the valve with ease by using the 68115 with the addition of a 13968 Rising Stem Torque Adapter.
- The 701061 counter assembly can be added to the 68115 and the 13968 for ease of valve revolution counting.

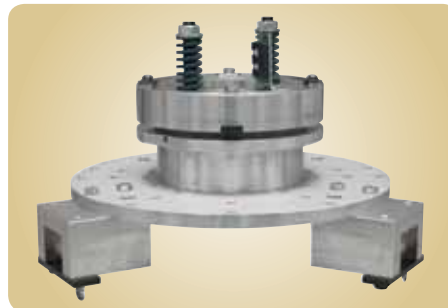

13968 and 13970 assembled.

VALVE KEYS

8806 6 FT. TELESCOPING VALVE KEY

Packed into a convenient 24" carrying case. Quick disconnect pull pins make adjustments fast and easy. Both a manual handle and a 1" square power adapter are included. 2" square female drive fits most standard valves. Telescopes to 6 ft.22 lbs. (10kg)

8808 8 FT. TELESCOPING VALVE KEY

Packed into a convenient 24" carrying case. Quick disconnect pull pins make adjustments fast and easy. Both a manual handle and a 1" square power adapter are included. 2" square female drive fits most standard valves. Telescopes to 8 ft.23 lbs. (10.5kg)

88024 2 FT. EXTENSION

To extend your 8806 6' key into an 8808 8' key9 lbs. (4.1kg)



WRENCHES, PLIERS & FASTENING TOOLS

Heavy Duty Iron Pipe Wrenches have I-Beam handles for proven strength and durability without excess weight. Full floating jaws have spring suspension for fast grip and release. Replaceable jaws are made of tough heat-treated alloy steel. Aluminum Wrenches are nearly 50% less weight compared to Iron Wrenches. The End Wrenches and the Off-Set Wrenches allow for usage in areas with space restrictions. All Pipe Wrenches are made to U.S. Federal Specifications. Parts are interchangeable with most major brands and carry a limited lifetime warranty.

HEAVY DUTY STRAIGHT IRON PIPE WRENCHES

Manufactured to U.S. Specifications GGG-W-651e Type II Class A

Model Number	Description	Pipe Capacity		Weight		Std Pack
		Inches	mm	lbs	Kg	
4508	8" (200mm) Straight Pipe Wrench	1	25	3/4	0.3	6
4510	10" (250mm) Straight Pipe Wrench	1 1/2	40	1 3/4	0.8	6
4512	12" (300mm) Straight Pipe Wrench	2	50	2 3/4	1.2	6
4514	14" (350mm) Straight Pipe Wrench	2	50	3 1/2	1.6	6
4518	18" (450mm) Straight Pipe Wrench	2 1/2	65	5 3/4	2.6	6
4524	24" (600mm) Straight Pipe Wrench	3	80	9 3/4	4.4	4
4536	36" (900mm) Straight Pipe Wrench	5	125	19	8.7	1
4548	48" (1200mm) Straight Pipe Wrench	6	150	34	15.5	1
4560	60" (1524mm) Straight Pipe Wrench	8	200	51 1/4	23.3	1

HEAVY DUTY END IRON PIPE WRENCHES

Manufactured to U.S. Specifications GGG-W-651e Type VI

Model Number	Description	Pipe Capacity		Weight		Std Pack
		Inches	mm	lbs	Kg	
4710	10" (250mm) End Pipe Wrench	1 1/2	40	1 3/4	0.8	6
4714	14" (350mm) End Pipe Wrench	2	50	3 1/2	1.6	6
4718	18" (450mm) End Pipe Wrench	2 1/2	65	5 3/4	2.6	3
4724	24" (600mm) End Pipe Wrench	3	80	9 3/4	4.4	1

ALUMINUM STRAIGHT PIPE WRENCHES

Manufactured to U.S. Specifications GGG-W-651e Type II Class C

Model Number	Description	Pipe Capacity		Weight		Std Pack
		Inches	mm	lbs	Kg	
4410	10" (250mm) Aluminum Straight	1 1/2	40	1	0.4	6
4414	14" (350mm) Aluminum Straight	2	50	2 1/2	1.1	6
4418	18" (450mm) Aluminum Straight	2 1/2	65	3 3/4	1.7	6
4424	24" (600mm) Aluminum Straight	3	80	6	2.7	6
4436	36" (900mm) Aluminum Straight	5	125	11	5	4
4448	48" (1200mm) Aluminum Straight	6	150	19	8.7	1

ALUMINUM OFF-SET PIPE WRENCHES

Manufactured to U.S. Specifications GGG-W-651 Type II Class C

Model Number	Description	Pipe Capacity		Weight		Std Pack
		Inches	mm	lbs	Kg	
4814	14" (350mm) Aluminum Off-Set	2	50	2	0.9	6
4818	18" (450mm) Aluminum Off-Set	2 1/2	65	3 1/2	1.6	6
4824	24" (600mm) Aluminum Off-Set	3	80	5	2.3	6



GRIPMASTER

The GripMaster is a one-handed operation wrench which provides a fast, secure grip. Spring-loaded jaws for fast placement on pipe and secure ratchet action.

Model Number	Description	Pipe Capacity		Weight		Std Pack
		Inches	mm	lbs	Kg	
4310	10" GripMaster	1 1/2	37.5	2	0.9	6
4314	14" GripMaster	2	50	4	1.8	6

SPUD WRENCH

The 4612 Spud Wrench is for 3/8" - 2 5/8" pipes and is designed with narrow jaws to fit into small spaces. The smooth jaws are the perfect tool when toothed jaws may not be the right choice for the job.

Model Number	Description	Pipe Capacity		Weight		Std Pack
		Inches	mm	lbs	Kg	
4612	12" Spud Wrench	2 5/8	67	2.7	1.2	6



DOUBLE-UP WRENCH

One through-bolt wrench with two sockets makes for fast, easy tightening of your repair clamp and service saddle nuts. Easy reversing with a single lever. Strong, all steel construction with a vinyl grip.

- 9600 1 1/4" x 1 1/16" Double-Up Wrench 2.75 lbs.
- 9601 1 5/16" x 1 1/8" Double-Up Wrench..... 2.75 lbs.

HEAVY DUTY DEEP SOCKETS

Designed for tightening hex nuts on repair clamps, mechanical joint fittings, and saddles. Large diameter barrels make fast hand tightening easy. Operates with any 1/2" drive manual or impact wrench. Eleven individual kits are available.

Individual Six Point Deep Sockets (Metric sizes listed in blue)

- 978 3/4" Deep Socket 6 pt. 1.1 lbs. (.5kg)
- 979 7/8" Deep Socket 6 pt. 1.1 lbs. (.5kg)
- 980 15/16" Deep Socket 6 pt. 1.1 lbs. (.5kg)
- 981 1 1/16" Deep Socket 6 pt. 1.1 lbs. (.5kg)
- 982 1 1/4" Deep Socket 6 pt. 1.1 lbs. (.5kg)
- 983 1 1/8" Deep Socket 6 pt. 1.1 lbs. (.5kg)
- 984 1 5/16" Deep Socket 6 pt. 1.1 lbs. (.5kg)
- 985 1 7/16" Deep Socket 6 pt. 1.1 lbs. (.5kg)
- 986 1" Deep Socket 6 pt. 1.1 lbs. (.5kg)
- 987 1 1/2" Deep Socket 6 pt. 1.1 lbs. (.5kg)
- 947 17mm Deep Socket 6 pt. 1.1 lbs. (.5kg)
- 943 19mm Deep Socket 6 pt. 1.1 lbs. (.5kg)
- 944 22mm Deep Socket 6 pt. 1.1 lbs. (.5kg)
- 945 24mm Deep Socket 6 pt. 1.1 lbs. (.5kg)
- 948 27mm Deep Socket 6 pt. 1.1 lbs. (.5kg)
- 946 30mm Deep Socket 6 pt. 1.1 lbs. (.5kg)

Kits Available with Deep Sockets in Tool Box with 6515 Ratchet as Follows:

- 960 Includes 980- 15/16", 981- 1 1/16", 982- 1 1/4" 10 lbs. (4.6kg)
- 961 Includes 980- 15/16", 981- 1 1/16", 982- 1 1/4", 983- 1 1/8" 11 lbs. (5kg)
- 962 Includes 980- 15/16", 982- 1 1/4", 983- 1 1/8" 10 lbs. (4.6kg)
- 963 Includes 981- 1 1/16", 982- 1 1/4", 984- 1 5/16", 985- 1 7/16" 11 lbs. (5kg)
- 964 Includes 981- 1 1/16", 982- 1 1/4", 983- 1 1/8" 10 lbs. (4.6kg)
- 965 Includes 979- 7/8", 981- 1 1/16", 982- 1 1/4" 10 lbs. (4.6kg)
- 966 Includes 978- 3/4", 979- 7/8", 980- 15/16", 981- 1 1/16" 11 lbs. (5kg)

Kits with Deep Sockets in Metric Sizes:

- 940 Includes 943- 19mm, 944- 22mm, 945- 24mm..... 10 lbs. (4.6kg)
- 941 Includes 943- 19mm, 944- 22mm, 945- 24mm, 946- 30mm 11 lbs. (5kg)
- 942 Includes 947- 17mm, 943- 19mm, 945- 24mm, 946- 30mm 11 lbs. (5kg)
- 950 Includes 947- 17mm, 943- 19mm, 944- 22mm, 945- 24mm, 948- 27mm, 946- 30mm..... 11 lbs. (5kg)



WRENCHES, PLIERS & FASTENING TOOLS CONTINUED

TWINTITE™

For torquing both screws simultaneously. The TwinTite™ attaches to most 3/8" reversible cordless drills. Fits couplings 1 1/2" to 4". Individual torque settings allow each clamp screw to be tightened to correct torque specification. The torque is preset to 60in lbs. or 80in lbs. and can be recalibrated with a torque wrench. The TwinTite™ is quick and easy to attach to your drill and the wire form can be bent to fit other drills.

1990	TwinTite™ 60in/lb. with 5/16" replacement socket.....	2.5 lbs.	(1.2kg)
1992	TwinTite™ 80in/lb. with 5/16" replacement socket.....	2.5 lbs.	(1.2kg)
1994	TwinTite™ 80in/lb. with 3/8" replacement socket.....	2.5 lbs.	(1.2kg)



Attachment procedure is 3 simple steps:

1. Place gear box shaft in drill chuck and tighten
2. Place wire form around drill handle and wire ends into clamp holes on bottom of gear box and tighten screws.
3. Assemble 2-piece clamp around wire form near drill handle base and tighten the screws.



SOIL PIPE COUPLING TORQUE WRENCH

This durable "T-Handle" type torque tool with a contoured comfort-fit handle features a removable socket and a unique locking collar, which allows the tool to be used as an untorqued snug-up or back-off, as well as a conventional torque tool. With the locking collar retracted, the tool torques to the right (tightening), while ratcheting to the left. When proper torque value has been achieved, the mechanism slips internally and over-tightening is impossible.



Replaceable Socket →

1977 T-Torque for tightening 5/16" coupling nuts to 60 in. lbs.....	Weight 1 lb. (.5kg)
1980 T-Torque for tightening 5/16" coupling nuts to 80 in. lbs.....	Weight 1 lb. (.5kg)
1981 T-Torque for tightening 3/8" coupling nuts to 80 in. lbs.....	Weight 1 lb. (.5kg)
1982 T-Torque for tightening 5/16" & 3/8" coupling nuts to 80 in. lbs.....	Weight 1 lb. (.5kg)

275410	5/16" Replacement Socket
275818	3/8" Replacement Socket

NO-HUB® COUPLING WRENCHES

Wheeler-Rex powered No-Hub® Coupling Wrenches tighten or loosen couplings in just a few seconds. The tools can be used with most 3/8" reversible electric drills. They can be installed and removed as quickly as a drill bit. Automatic clutch in torque heads prevent over and under tightening. Recalibration is easy with a torque wrench.



1964 "Fastite"		
For tightening 5/16" coupling nuts to 60 in. lbs.	Shipping weight	9 oz.
1965 "Fastite Plus"		
For tightening 3/8" coupling nuts to 80 in. lbs.	Shipping weight	9 oz.
1966 "Fastite Plus 2"		
For tightening 5/16" coupling nuts to 80 in. lbs.	Shipping weight	9 oz.
1974 "Fastite Two"		
For tightening 1/4" coupling nuts to 80 in. lbs.	Shipping weight	9 oz.



BASIN WRENCH

Quickly & easily tightens or loosens faucet shank nuts in close quarters. Complete with spring loaded jaws and a telescopic handle that adjusts from 10 to 17 inches and a friction plug that helps hold the head in position. $\frac{3}{8}$ " to $1\frac{1}{4}$ " capacity.

- 9400 Shipping weight 2 lbs.
- 9401 Same as 9400 except with non-telescopic handle 2 lbs.

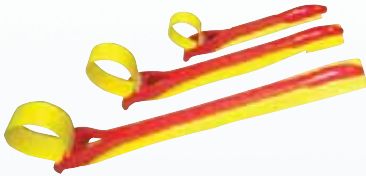

STRAP WRENCHES

Provides quick gripping to plastic or chrome plated objects without scratching or damaging the surface. Neoprene Coated Strap. Ductile iron handles for high strength.

Model No.	Pipe capacity	O.D. Capacity	Handle Length
8312	$\frac{1}{8}$ "–2" (10–63mm)	$\frac{1}{8}$ "– $3\frac{1}{2}$ " (10–90mm)	12" (305mm) weight 2.0 lbs.
8318	1"–5" (33–127mm)	1"–6" (33–150mm)	18" (458mm) weight 3.3 lbs.
8324	2"–12" (60–324mm)	2"–14" (60–350mm)	24" (610mm) weight 5.7 lbs.
83120	Replacement Strap for 8312		
83180	Replacement Strap for 8318		
83240	Replacement Strap for 8324		



ALUMINUM VALVE WHEEL WRENCHES

Designed to provide leverage to turn a valve wheel without slipping. Made from aluminum to be light weight and non-sparking. Three convenient sizes for added leverage.

- 8708 8" Length ($\frac{3}{4}$ " Mouth Opening) Shipping weight 6 oz.
- 8714 14" Length (1" Mouth Opening) Shipping weight 1 lb.
- 8718 18" Length ($1\frac{3}{8}$ " Mouth Opening) Shipping weight 2.5 lbs.

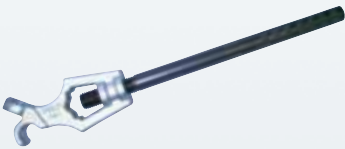

HYDRANT WRENCH

For removing hydrant caps and operating hydrants. Made of sturdy forged construction; will fit pentagon nuts up to $1\frac{3}{4}$ " or square nuts up to $1\frac{1}{4}$ " with spanners for either pin or lug style host couplings.

- 8700 Hydrant Wrench 5 lbs. (2.5kg)



5400 LIGHT DUTY CHAIN WRENCH

With forged alloy steel handles, the 5400 is ideal for use in small locations. The 5400 is designed for pipes up to 4" O.D. Chain length is $15\frac{3}{4}$ "; handle length is 12".

- Weight 2.5 lbs. (1.2kg)



UTILITY PLIERS

Waterpump style, with hardened anti-slip teeth on all jaw surfaces, create outstanding gripping and holding power. Unique cam/channel jaw positioning system permits fast, easy adjustments, along with wide comfort-fit handle.

- 1910 10" length $1\frac{1}{4}$ " jaw capacity Shipping weight 1 lb.
- 1912 12" length $1\frac{7}{8}$ " jaw capacity Shipping weight 2 lbs.
- 1916 16" length $2\frac{1}{2}$ " jaw capacity Shipping weight 3 lbs.

CRIMPING TOOLS



CRIMPING TOOLS

Wheeler-Rex introduces a line of crimping tools specifically designed to help install better connections on PEX potable water or radiant heating systems. The full circle crimp eliminates the unsightly appearance of tool marks and distortion of crimped rings.

89202 1/2" PEX RING CRIMPER

A PEX Ring Crimper for 1/2". Crimps conform to ASTM specifications and is supplied with a go/no-go gauge. Complete with a soft, comfortable grip. OAL 12"
 Shipping weight.....3 lbs. (1.5kg)

89203 3/4" PEX RING CRIMPER

A PEX Ring Crimper for 3/4". Crimps conform to ASTM specifications and is supplied with a go/no-go gauge. Complete with a soft, comfortable grip. OAL 12"
 Shipping weight.....3 lbs. (1.5kg)

89204 1" PEX RING CRIMPER

A PEX Ring Crimper for 1". Crimps conform to ASTM specifications and is supplied with a go/no-go gauge. Complete with a soft, comfortable grip and long handles for extra leverage. OAL 19"
 Shipping weight..... 5 lbs. (2.3kg)

89206 1/2" AND 3/4" PEX COMBO CRIMPER

A Combination Pex Ring Crimper for 1/2" and 3/4". Crimps conform to ASTM specifications and is supplied with a go / no-go gauge. Complete with a soft, comfortable grip and long handles for extra leverage. OAL 16"
 Shipping weight..... 5 lbs. (2.3kg)

STAINLESS CLAMP PINCHER RATCHET TOOL

The PEX Stainless Clamp Pincher Ratchet Tool with a full cycle mechanism assures consistent water tight crimps, eliminating the need for a crimp gauge. Made from heat treated steel for strength and durability. Its compact design and lightweight frame allow this tool to be extremely versatile when used in confined areas.

Our PEX Stainless Clamp Pincher ratchet tool can be used for 3/8", 1/2", 3/4" and 1". Crimps conform to ASTM F2098 specifications. OAL 11"

89250 Stainless Clamp Pincher, Shipping weight..... 1 lb. (.5kg)

PEX RING REMOVER

This unique tool is designed for fitting recovery without damaging the fittings. The high mechanical advantage makes shearing of rings much easier and faster than sawing off a crimped ring. Just two cuts on the ring allow the user to reclaim the fitting. Saves time and money!!

89210 1/2"-1" Ring Remover, Shipping weight1.5 lbs. (.7kg)
 892100 Replacement Cutting Blade



CLOSE QUARTERS CRIMP TOOLS

A unique tool designed for 1/2" and 3/4" pipe sizes. These tools provide a toggle action which helps to assure a complete crimp cycle. Light weight with a comfort fit handle, it's high mechanical action allows one hand crimping to ASTM specifications. OAL 12"

- 89215 1/2" Close Quarters Crimp Tool 2 lbs.
- 89216 3/4" Close Quarters Crimp Tool 2 lbs.



89217 CLAMP CRIMPER

The Close Quarters Tool crimps rings to ASTM F-1087 on 3/8", 1/2", 3/4", and 1" pipe. A wrench is used to torque the bolts down until the gap is eliminated. Convenient 1" and 3/4" on one side, flip over and 1/2" and 3/8" on the reverse. Complete with a gauge to assure crimps are to specifications. OAL 3 1/2"

Weight..... 1.5 lbs.



89211 CLAMP REMOVAL TOOL

This unique tool allows fitting recovery with an effortless torquing action. Apply the socket to a "T" bar or socket wrench and place over the pinched clamp. By turning 90 degrees in a clockwise action and then counter-clockwise the clamp is sheared making fitting recovery quick and easy. Remove all clamps 3/8", 1/2", 5/8", 3/4" and 1" with ONE tool. Wrench nut supplied.

Weight..... 2 lbs.



89220 CRIMP KIT

A 1" Crimp Tool with interchangeable die inserts. Kit comes with 1/2", 3/4" and 1" inserts in a convenient carrying case with a crimp gauge. Optional 3/8" and 5/8" inserts are available. Die inserts are easily changed without tools. No calibration procedure is required and all crimps conform to ASTM F-1807 specifications. Kit includes the 89210 Ring Remover.

Weight..... 8.5 lbs.

DIE SETS

892201	3/8" Die Set for 89220
892202	1/2" Die Set for 89220
892203	5/8" Die Set for 89220
892204	3/4" Die Set for 89220

MISCELLANEOUS TOOLS



7100 HACK SAWS AND BLADES

The Model 7100 Hack Saw is a high tension hacksaw for plumbers, electricians and maintenance workers. Built-in storage in handle for 10 blades.

7100 Hack Saw Weight 1.8 lbs. (.8kg)

Features:

- Aluminum construction
- Powder coat finish
- Ergonomic design
- BiMetal blade included

Replacement Blades

Wheeler #	Blade Size	Teeth per inch	Weight
7114	12 x 1/2 x .025	14	.05 lb. (.02kg)
7118	12 x 1/2 x .025	18	.05 lb. (.02kg)
7124	12 x 1/2 x .025	24	.05 lb. (.02kg)
7132	12 x 1/2 x .025	32	.05 lb. (.02kg)

Blades priced individually but sold in 10 packs only.

MULTI-PURPOSE 6-IN-1 SCREWDRIVER

Comfortable grip handle and includes the following:

- #1 and #2 Phillips® tips
- 3/16" and 1/4" flat tips
- 5/16" and 1/4" nut drivers in the shaft

Sold separately or in a convenient 12 pack display.

6018 6-in-1 Screwdriver Weight .5 lb. (.23kg)
 6019 12-Pack Display of 6018 Weight 6 lbs. (2.7kg)

DIAMETER TAPE

For measuring diameter or circumference of pipes and cylindrical objects.

71 Pocket size 6' (1.82m) linear / 22" (.56m) Diameter Tape.
 English/Metric Scales. Weight 6 oz.



DISTRIBUTOR MARKETING AIDS



998008 Pipe Wrench Display Board with Pipe Wrench 4514, 4714, 4414 & 4814 (14 lbs.)



998025 Generic Tool Mat



998014 Tubing Tools Display Board with 7290, 5290, 5190, 90750, 90735, 90728 & 90722 (11 lbs.)



998005 Universal Replacement Die Center your choice of dies (Approx. 16 lbs.)



998015 Combination Die Display your choice of dies (Approx. 6 lbs.)



998006 12R Style Replacement Die Center your choice of dies (Approx. 7 lbs.)



998004 Pipeline Counter Mat



998010 Waterworks Counter Mat

All displays can be hung on either slot wall or pegboard!



The fastest growing line of professional tools & equipment...



Pipe Cutters



Plastic Pipe Tools



Tube Tools

...for the construction, industrial, municipal & water works markets.



Threading Machines



Hydrostatic Test Pumps



Drilling & Tapping Tools

- Pipe cutters
- Pipe fabrication
- Threading machines
- Dies
- Hydrostatic test pumps
- Trash pumps
- Tube tools
- Cutter wheels
- Glass tubing cutters
- Plastic pipe tools
- Pipe working tools
- Shut-off tools
- Pipe freezing kits
- Drilling & tapping tools
- Wrenches
- Pliers
- Fastening tools
- Valve exercisers

PRODUCT INDEX

Part No.	Description	Page	Part No.	Description	Page
70	SHUT OFF TOOL 1 1/4" THRU 2"	46	1660	HOLE CUTTER, GAS ENGINE	50
71	ENGLISH/METRIC 6 FT DIAMETER TAPE	60	1661	HOLE CUTTER AIR MOTOR	50
75	PLASTIC WATER PIPE SHUT OFF TOOL	46	1662	HOLE CUTTER ELECTRIC MOTOR	50
77	PLASTIC GAS PIPE SHUT OFF TOOL W/STOPS	46	1663	HOLE CUTTER HYDRAULIC POWER	50
85	SHUT OFF TOOL, 3/4"-1"	46	1664	HOLE CUTTER SYSTEM LESS DRIVE	50
86	SHUT OFF TOOL, 1/2"-1"	46	1694	T-HANDLE GUILLOTINE CUTTER 8" MAX O.D.	43
450	TUBE CLEANING BRUSH	33	1755	3/8"-2 3/8" FREEZE KIT	47
600	PLASTIC PIPE SAW, 18" BLADE	40	1890	POWER GUILLOTINE CUTTER 13.2" MAX O.D. (power capable)	43
601	PLASTIC PIPE SAW, 18" TEFLON BLADE	40	1892	T-HANDLE GUILLOTINE CUTTER 13.2" MAX O.D.	43
602	PLASTIC PIPE SAW, 12" BLADE	40	1910	10" WATERPUMP PLIERS	57
603	PLASTIC PIPE SAW, 12" TEFLON BLADE	40	1912	12" WATERPUMP PLIERS	57
610	18" BLADE ONLY FOR 600	40	1916	16" WATERPUMP PLIERS	57
611	18" TEFLON COATED BLADE FOR 601	40	1964	5/16" FASTITE TORQUE WRENCH, 60" lbs.	56
612	13" BLADE ONLY FOR 602	40	1965	3/8" FASTITE TORQUE WRENCH, 80" lbs.	56
613	13" TEFLON COATED BLADE FOR 603	40	1966	5/16" FASTITE TORQUE WRENCH, 80" lbs.	56
626	26" CABLE SAW	40	1974	1/4" FASTITE TORQUE WRENCH, 80" lbs.	56
636	36" CABLE SAW	40	1977	5/16" TORQUE WRENCH, 60" lbs.	4, 56
640	POWER DRIVE W/CASE, ADAPTER	16	1980	5/16" TORQUE WRENCH, 80" lbs.	4, 56
641	POWER DRIVE W/WISE, ADAPTER	16	1981	3/8" TORQUE WRENCH, 80" lbs.	4, 56
726	26" HAND SAW FOR PVC PIPE	40	1982	5/16" & 3/8" TORQUE WRENCH, 80" lbs.	4, 56
727	REPLACEMENT BLADE FOR 726	40	1990	5/16" TWINTITE, 60" lbs.	56
730	26" HAND SAW FOR PVC PIPE, TEFLON BLADE	40	1992	5/16" TWINTITE, 80" lbs.	56
731	REPLACEMENT BLADE FOR 730	40	1994	3/8" TWINTITE, 80" lbs.	56
841	STAND FOR 7991	21	2290	INTERNAL PIPE CUTTER, 2"	42
850	FOLDING PIPE STAND W/ V HEAD	44	2490	51mm I.D. PVC IPC	42
851	FOLDING PIPE STAND W/BT HEAD	44	2492	2" SCH 80 PVC IPC	42
880	PIPE DOLLIE	45	2500	KWIKSNAP SEMI AUTO CI CUTTER	8
892	T-HANDLE GUILLOTINE CUTTER 4" MAX O.D.	43	2525	KWIK SNAP TABLE	9
920	DEBURRING TOOL	36	2526	3' TABLE SECTION ASSY FOR 2525	9
921	10 PACK DEBURRING TOOL	36	2527	TABLE LEG / COUPLING ASSEMBLY	9
940	HD METRIC DS SET 19, 22, 24mm	55	2690	1/8"-2" STEEL PIPE CUTTER	7
941	HD METRIC DS SET 19, 22, 24, 30mm	55	3090	HOLE CUTTER W/MILW ADAPTER	49
942	HD METRIC DS SET 17, 19, 24, 30mm	55	3091	HOLE CUTTER W/DEWALT ADAPTER	49
943	HD 19mm DEEP SOCKET	55	3092	3090 HOLE CUTTER W/MILWAUKEE DRILL	49
944	HD 22mm DEEP SOCKET	55	3093	3091 HOLE CUTTER W/DEWALT DRILL	49
945	HD 24mm DEEP SOCKET	55	3290	INTERNAL PIPE CUTTER, 3"	42
946	HD 30mm DEEP SOCKET	55	3395	DIAMOND CUTTER SHELL, 3 7/8"	50
947	HD 17mm DEEP SOCKET	55	3450	DIAMOND CUTTER SHELL, 4 1/2"	50
948	HD 27mm DEEP SOCKET	55	3490	INTERNAL PIPE CUTTER, 3" SCH 80	42
950	HD METRIC DS SET 17, 19, 22, 24, 27, 30mm	55	3590	SMALL RATCH CUT W/METAL HANDLE	34
960	HD DS KIT 15/16", 1 1/16", 1 1/4"	55	3595	DIAMOND CUTTER SHELL, 5 7/8"	50
961	HD DS KIT 15/16", 1 1/16", 1 1/8", 1 1/4"	55	3650	DIAMOND CUTTER SHELL, 6 1/2"	50
962	HD DS KIT 15/16", 1 1/8", 1 1/4"	55	3790	LARGE RATCH CUT W/METAL HANDLE	34
963	HD DS KIT 1 1/16", 1 1/4", 1 5/16", 1 7/16"	55	3801	WHEELER HYDROYL QUART	5
964	HD DS KIT 1 1/16", 1 1/8", 1 1/4", 1 5/16"	55	3804	WHEELER HYDROYL GALLON	5
965	HD DS KIT 7/8", 1 1/16", 1 1/4"	55	4006	PIPE VISE	45
966	HD DS KIT 3/4", 7/8", 15/16", 1 1/16"	55	4012	PIPE PULLER	45
978	3/4" HD DEEP SOCKET	55	4015	PIPE VISE	45
979	7/8" HD DEEP SOCKET	55	4020	PIPE VISE	45
980	15/16" HD DEEP SOCKET	55	4028	PIPE VISE	45
981	1 1/16" HD DEEP SOCKET	55	4060	6" PLUG POPPER	45
982	1 1/4" HD DEEP SOCKET	55	4080	8" PLUG POPPER	45
983	1 1/8" HD DEEP SOCKET	55	4160	TRISTAND CHAIN VISE, 1/8"-6"	44
984	1 5/16" HD DEEP SOCKET	55	4190	MICRO SNIPPER	39
985	1 7/16" HD DEEP SOCKET	55	4200	1/2"-2" MANUAL THREADER SET	16
986	1" HD DEEP SOCKET	55	4202	1/2"-1" MANUAL THREADER SET	16
987	1 1/2" DEEP SOCKET	55	4207	1/2"-1 1/4" NPT MANUAL THREADER SET	16
1300	PIPE SCRAPER, 3"-12"	7	4209	1/2"-2" NPSM MANUAL THREADER SET	16
1350	PIPE SCRAPER, 12"-36"	7	4211	1"-2" NPT MANUAL THREADER SET	16
1590	INTERNAL PIPE CUTTER, 1 1/2"	42	4213	4200 MANUAL THREADER LESS TOOL BOX	16

PRODUCT INDEX

CONTINUED

Part No.	Description	Page
4215	1/2"-2" BSPT MANUAL THREADER SET	16
4290	INTERNAL PIPE CUTTER, 4"	42
4310	10" GRIPMASTER PIPE WRENCH	55
4314	14" GRIPMASTER PIPE WRENCH	55
4395	PVC CUTTER SHELL, 3 7/8"	50
4410	10" ALUMINUM STRAIGHT PIPE WRENCH	54
4414	14" ALUMINUM STRAIGHT PIPE WRENCH	54
4418	18" ALUMINUM STRAIGHT PIPE WRENCH	54
4424	24" ALUMINUM STRAIGHT PIPE WRENCH	54
4436	36" ALUMINUM STRAIGHT PIPE WRENCH	54
4448	48" ALUMINUM STRAIGHT PIPE WRENCH	54
4450	PVC CUTTER SHELL, 4 1/2"	50
4490	INTERNAL PIPE CUTTER, 4"	42
4506	6-IN-1 COPPER TUBE BRUSH/REAMER	33
4508	8" HD STRAIGHT IRON PIPE WRENCH	54
4510	10 HD STRAIGHT IRON PIPE WRENCH	54
4512	12" HD STRAIGHT IRON PIPE WRENCH	54
4514	14" HD STRAIGHT IRON PIPE WRENCH	54
4518	18" HD STRAIGHT IRON PIPE WRENCH	54
4524	24" HD STRAIGHT IRON PIPE WRENCH	54
4536	36" HD STRAIGHT IRON PIPE WRENCH	54
4548	48" HD STRAIGHT IRON PIPE WRENCH	54
4560	60" HD STRAIGHT IRON PIPE WRENCH	54
4590	5/8" O.D. SELF FEED RATCH CUT	34
4595	PVC CUTTER SHELL, 5 7/8"	50
4606	6" DIAMOND BLADE FOR DI & CI, PIPEMASTER	10
4612	12" SPUD WRENCH	55
4616	6" DIAMOND ECONOMY BLADE PIPEMASTER	10
4624	PIPEMASTER, 6"-24"	10
4648	PIPEMASTER, 6"-48"	10
4650	PVC CUTTER SHELL, 6 1/2"	50
4690	2"-4" MANUAL STEEL PIPE CUTTER	7
4700	HAMMERHEAD FLARING KIT	36
4705	5" TCT BLADE FOR STEEL, PIPEMASTER	10
4706	6 1/2" TCT BLADE FOR STEEL, PIPEMASTER	10
4710	10" HD END IRON PIPE WRENCH	54
4714	14" HD END IRON PIPE WRENCH	54
4718	18" HD END IRON PIPE WRENCH	54
4724	24" HD END IRON PIPE WRENCH	54
4790	7/8" O.D. SELF FEED RATCH CUT	34
4800	PVC CUTTER SHELL, 8"	50
4814	14" ALUMINUM OFF SET PIPE WRENCH	54
4818	18" ALUMINUM OFFSET PIPE WRENCH	54
4824	24" ALUMINUM OFFSET PIPE WRENCH	54
4900	3/4"-2" REROUNDING TOOL KIT	36
4906	RATCHET PIPE CUTTER, 2"-6"	4
4908	RATCHET PIPE CUTTER, 2"-8"	4
4916	490 RATCHET PIPE CUTTER W/519 KIT	4
4918	490 RATCHET PIPE CUTTER W/519 KIT	4
4991	CLOSE QUARTERS CUTTER	33
5090	PIPE CUTTER, 1/2"-2"	7
5190	MINI SNIPPER	39
5191	MINI SNIPPER W/TEFLON BLADE	39
5195	1/8"-1 1/4" ECONOMY MINI SNIPPER	39
5290	PLASTIC PIPE CUTTER	39
5295	1/8"-1 5/8" ECONOMY CUTTER	39
5400	CHAIN WRENCH	57
5412	OPC 4"-12" CUT & GRV STL & ALUM	13
5690	AUTO-C CUTTER, 1/2"	33
5691	AUTO-C CUTTER, 3/4"	33

Part No.	Description	Page
5692	AUTO-C CUTTER, 1"	33
5900	OIL BUCKET W/PUMP	16
5906	MANUAL PIPE CUTTER, 2"-6"	4
5908	MANUAL PIPE CUTTER, 2"-8"	4
5916	590 MANUAL PIPE CUTTER W/519	4
5918	590 MANUAL PIPE CUTTER W/519	4
6000	INTERNAL PIPE CUTTER, 6"	42
6018	6-IN-1 COMFORT GRIP SCREWDRIVER	60
6019	12 PACK, 6018 SCREWDRIVERS	60
6090	THREADING MACHINE, 1/2"-2"	19
6395	RC DIAMOND CUTTER SHELL, 3 7/8"	50
6450	RC DIAMOND CUTTER SHELL, 4 1/2"	50
6500	HYDRAULIC POWER PACK	11
6590	THREADING MACHINE, 2 1/2"-6"	20
6595	RC DIAMOND CUTTER SHELL, 5 7/8"	50
6600	1 1/2"-6" MANUAL GROOVER	12
6601	COPPER GROOVER (6600)	12
6412	OPMT CUT & BEVEL DIP, 4"-12"	13
6650	RC DIAMOND CUTTER SHELL, 6 1/2"	50
6790	THREADING MACHINE, 1/2"-4"	20
6793	6790 W/NOTCH TYPE DIE HEADS	20
6794	6790 W/BLADE TYPE CUTTER ARM	20
6800	RC DIAMOND CUTTER SHELL, 8"	50
7100	HI-TENSION HACKSAW	60
7290	2" SUPER SNIPPER, 2 3/8" O.D.	39
7325	BLADE SHARPENER	39
7702	ROLL GROOVING MACHINE W/MANUAL	13
7703	ROLL GROOVING MACHINE W/POWER	13
7800	EARTH WORM HYDRO DRILL	50
7890	THREADING MACHINE, 1/2"-1 1/2"	19
7991	SIDEKICK II, 1/2"-1" PIPE THREADER	18
7992	SIDEKICK II, W/60131 DIE HEAD	18
7993	SIDEKICK II, WITH 2 #70131	18
7998	SIDEKICK II, 1/2"-1" PIPE THREADER 220V	18
8090	PIPE THREADING MACHINE, 1/2"-2"	19
8096	8090 W/2 DIE HEADS	19
8097	8090 W/897065 MANUAL DIE HEAD	19
8100	DRILLING MACHINE, 3/4" & 1" NPT	48
8200	DRILLING MACHINE, 3/4" & 1" CTS	48
8300	DRILLING MACHINE, 3/4" & 1" BSPT	48
8312	12" STRAP WRENCH, 1/2"-2" PIPE	57
8318	18" STRAP WRENCH, 1"-5" PIPE	57
8324	24" STRAP WRENCH, 2"-12" PIPE	57
8400	ROLL GROOVER FOR 6090/7090	12
8401	ROLL GROOVER FOR 300	12
8402	ROLL GROOVER FOR 300 COMPACT	12
8403	ROLL GROOVER FOR 6790	12
8412	OPMT CUT & BEVEL STEEL PIPE	13
8415	MANTIS 180 WS CHAIN VISE BAND	14
8416	MANTIS 180 WA FLAT VISE BAND	14
8500	MINI SLICE PIPELINE	51
8520	MINISLICE W/50' CABLE & GRIP	51
8521	MINISLICE W/75' CABLE & GRIP	51
8522	MINISLICE W/100' CABLE & GRIP	51
8570	MODEL 85 & 70 COMBO SHUT OFF TOOL	46
8600	PIPE SLICE	51
8601	PIPESLICE II	51
8610	CABLE GRIP	51
8620	PIPESLICE II, 8605, 8610	51
8621	PIPESLICE II, 8606, 8610	51

Part No.	Description	Page	Part No.	Description	Page
8622	PIPESLICE II, 8607, 8610	51	29900	MANUAL TEST PUMP, W/TANK	28
8623	PIPESLICE II, 8608, 8610	51	29906	2"– 6" HYDRAULIC PIPE CUTTER	5
8627	8600 PIPE SLICE, 8605 50' CABLE, 8610 GRIP	51	29908	2"– 8" HYDRAULIC PIPE CUTTER	5
8628	8600 PIPE SLICE, 8606 75' CABLE, 8610 GRIP	51	30050	1/2" IPS BEVEL TOOL/ DEPTH GAUGE	42
8629	8600 PIPE SLICE, 8607 100' CABLE, 8610 GRIP	51	30075	3/4" IPS BEVEL TOOL/ DEPTH GAUGE	42
8630	8600 PIPE SLICE, 8608 150' CABLE, 8610 GRIP	51	30100	1" IPS BEVEL TOOL/ DEPTH GAUGE	42
8640	PIPESLICE II, w/8645, 8646, 8648	51	30125	1 1/4" IPS BEVEL TOOL/DEPTH GAUGE	42
8641	PIPESLICE II, w/8645, 8646	51	30150	1 1/2" IPS BEVEL TOOL/DEPTH GAUGE	42
8642	PIPESLICE II, w/8648, 8649	51	30200	2" IPS BEVEL TOOL/DEPTH GAUGE	42
8670	MODEL 86 & 70 COMBO SHUT OFF TOOL	46	32150	PNEUMATIC HYDRO TEST PUMP	31
8700	FORGED HYDRANT WRENCH	57	32300	PNEUMATIC HYDRO TEST PUMP	31
8708	8" ALUMINUM VALVE WHEEL WRENCH	57	32900	3" CAPITOL STYLE CI CUTTER	7
8714	14" ALUMINUM VALVE WHEEL WRENCH	57	33100	ELECTRIC TEST PUMP, 1000 psi	30
8718	18" ALUMINUM VALVE WHEEL WRENCH	57	33101	33100 W/220V 50Hz MOTOR	30
8806	6 FT ADJUSTA-KEY	53	35100	ELECTRIC TEST PUMP, 500 psi	30
8808	8 FT ADJUSTA-KEY	53	35101	ELECTRIC TEST PUMP, 220V, 50Hz	30
8900	SLIK-TAP DIRECT TAP LUBRICANT	49	36454	HYDROSTATIC TEST PUMP, 10 gpm 400 psi B&S	29
8901	SLIK-TAP, 12 PACK CASE	49	37204	ELECTRIC TEST PUMP, 3.5 gpm 3000 psi	31
9000	POWER PLASTIC BEVELER	40	39300	TEST PUMP, 300 psi 4 gpm 1/2 hp.	30
9001	MODEL 9000 WITH CARBIDE BIT	40	39301	39300 TEST PUMP, 220V, 60Hz	30
9015	PLASTIC PIPE BEVEL TOOL	40	39906	HD RATCHET PIPE CUTTER. 2"– 6"	4
9050	PNEUMATIC PLASTIC PIPE BEVELER	40	39908	HD RATCHET PIPE CUTTER, 2"– 8"	4
9400	TELESCOPING BASIN WRENCH	57	40020	20mm POLY PIPE CHAMFER TOOL	42
9401	STANDARD BASIN WRENCH	57	40025	25mm POLY PIPE CHAMFER TOOL	42
9600	1 1/4" X 1 1/16" DOUBLE-UP WRENCH	55	40032	32mm POLY PIPE CHAMFER TOOL	42
9601	1 5/16" X 1 1/8" DOUBLE-UP WRENCH	55	40040	40mm POLY PIPE CHAMFER TOOL	42
9700	HYDRAULIC ROLL GROOVER FOR 6090, 7090, 8090	12	40050	50mm POLY PIPE CHAMFER TOOL	42
9701	HYDRAULIC ROLL GROOVER W/ BASE FOR 6790	12	40063	63mm POLY PIPE CHAMFER TOOL	42
9703	HYDRAULIC ROLL GROOVER W/ BASE FOR 300	12	42900	4" CAPITOL STYLE CI CUTTER	7
10050	1/2" CTS BEVEL TOOL/DEPTH GAUGE	42	46200	HYDROSTATIC TEST PUMP, 3.5 gpm 1200 psi B&S	29
10075	3/4" CTS BEVEL TOOL/DEPTH GAUGE	42	46301	HYDROSTATIC TEST PUMP, 5.4 gpm 300 psi	29
10100	1" CTS BEVEL TOOL/DEPTH GAUGE	42	46453	HYDROSTATIC TEST PUMP, 10 gpm 400 psi B&S	29
10125	1 1/4" CTS BEVEL TOOL/DEPTH GAUGE	42	46501	HYDROSTATIC TEST PUMP, 10 gpm 500 psi B&S	29
10150	1 1/2" CTS BEVEL TOOL/DEPTH GAUGE	42	46600	HYDROSTATIC TEST PUMP, 15 gpm 300 psi B&S	30
10200	2" CTS BEVEL TOOL/DEPTH GAUGE	42	46701	46501 TEST PUMP W/TANK, 10 gpm 500 psi B&S	30
13020	2" HINGED PIPE VISE	45	46800	HYDROSTATIC TEST PUMP, 26 gpm 250 psi B&S	30
13040	2 1/2" HINGED PIPE VISE	45	47100	ELECTRIC TEST PUMP, 2.2 gpm 1000 psi 115V 60Hz	31
13060	4" HINGED PIPE VISE	45	47102	ELECTRIC TEST PUMP, 1.1 gpm 2000 psi 115V 60Hz	31
13080	5" HINGED PIPE VISE	45	47103	ELECTRIC TEST PUMP, 1.1 gpm 2000 psi 220V 50Hz	31
13964	SAFETY ADAPTER W/COUNTER	52	47105	ELECTRIC TEST PUMP, 2.2 gpm 2000 psi 115v 60hz	31
13968	RISING STEM TORQUE ADAPTOR	53	49010	RATCHET PIPE CUTTER, 10"	4
13970	RISING STEM HAND WHEEL ADAPTOR	53	49012	RATCHET PIPE CUTTER, 12"	4
16010	1 1/2"– 4" PIPE HOG KIT SCH 40	41	49015	RATCHET PIPE CUTTER, 15"	4
16150	1 1/2" PIPE HOG SCH 40	41	49075	3/4" REROUNDING TOOL	36
16200	2" PIPE HOG SCH 40	41	49100	1" REROUNDING TOOL	36
16300	3" PIPE HOG SCH 40	41	49150	1 1/2" REROUNDING TOOL	36
16400	4" PIPE HOG SCH 40	41	49200	2" REROUNDING TOOL	36
17010	FITTING SAVER KIT, SCH 40	41	50100	INNER/OUTER REAMER, 3/8"– 2"	36
17020	FITTING SAVER KIT, SCH 80	41	56200	2" TRASH PUMP	32
17050	1/2" PVC FITTING SAVER, SCH 40	41	56201	SAME AS 56200 WITH WHEELED CART	32
17051	1/2" IPS FITTING SAVER, SCH 80	41	56300	3" TRASH PUMP	32
17075	3/4" PVC FITTING SAVER, SCH 40	41	56301	SAME AS 56300 WITH WHEELED CART	32
17076	3/4" IPS FITTING SAVER, SCH 80	41	56310	3" MUDSUCKER DIAPHRAGM PUMP	32
17100	1" PVC FITTING SAVER, SCH 40	41	56400	4" TRASH PUMP, B&S VANGUARD	32
17101	1" PVC FITTING SAVER, SCH 80	41	59010	MANUAL PIPE CUTTER, 10"	4
17500	REPLACEMENT POLAR GAS CANISTER	47	59012	MANUAL PIPE CUTTER, 12"	4
18050	1/2" CTS FITTING SAVER	41	59015	MANUAL PIPE CUTTER, 15"	4
18075	3/4" CTS FITTING SAVER	41	60504	COLLAPSIBLE CART FOR MANTIS	15
29200	MANUAL TEST PUMP, 300 psi	28	60506	WHEELED CART FOR 6790	21
29201	MANUAL TEST PUMP, 1000 psi	28	60507	WHEELED CART W/TOOL BOX 6790	21

PRODUCT INDEX

CONTINUED

Part No.	Description	Page
60508	COLLAPSIBLE THREADER CART, 7090	21
60509	COLLAPSIBLE THREADER CART, 6090	21
60512	COLLAPSIBLE THREADER CART, 300	21
60513	COLLAPSIBLE THREADER CART, 8090	21
60514	WHEELED CART FOR 6590	21
60515	WHEELED CART W/TOOL BOX FOR 6590	21
60601	THREADMASTER OIL, 1 GALLON	21
60602	THREADMASTER OIL, 5 GALLON	21
60603	THREADMASTER OIL, 2 QUART	21
60604	THREADMASTER OIL, 1 QUART	21
60655	THREADMASTER OIL, 55 GALLON DRUM	21
62000	NIPPLE CHUCK, 1/2" NPT	21
62001	NIPPLE CHUCK, 3/4" NPT	21
62002	NIPPLE CHUCK, 1" NPT	21
62003	NIPPLE CHUCK, 1 1/4" NPT	21
62004	NIPPLE CHUCK, 1 1/2" NPT	21
62005	NIPPLE CHUCK, 2" NPT	21
62006	NIPPLE CHUCK, 2 1/2" NPT	21
62007	NIPPLE CHUCK, 3" NPT	21
62009	NIPPLE CHUCK, 4" NPT	21
64200	640/4200 COMBO PACK	16
68115	POWER DRIVE, 115V 68A	52
69012	GLASS TUBE CUTTER	38
79014	GLASS TUBE CUTTER	38
79022	GLASS TUBE CUTTER	38
80115	SAFETY TORQUE VISE	16
86075	3/4" CC PVC DRILL TAP	49
86100	1" CC PVC DRILL TAP	49
87050	1/2" NIPPLE CHUCK/INT WRENCH	21
87075	3/4" NIPPLE CHUCK/INT WRENCH	21
87100	1" NIPPLE CHUCK/INT WRENCH	21
87101	SET OF NIPPLE CHUCKS, 1/2"-1"	21
88024	2 FT VALVE KEY EXTENSION	53
89075	3/4" DRILL TAP	49
89100	1" DRILL TAP	49
89202	1/2" PEX RING CRIMPER	58
89203	3/4" PEX RING CRIMPER	58
89204	1" PEX RING CRIMPER	58
89206	1/2" & 3/4" PEX COMBO CRIMPER	58
89210	1/2"-1" RING REMOVER	58
89211	CLAMP REMOVAL TOOL	59
89215	1/2" CLOSE QUARTERS CRIMP TOOL	59
89216	3/4" CLOSE QUARTERS CRIMP TOOL	59
89217	COMBO CLAMP STYLE CRIMPER	59
89220	CRIMP KIT, 1/2", 3/4" & 1"	59
89250	SS CLAMP PINCHER	58
90722	MINI TUBE CUTTER, 1/4"-7/8"	35
90728	MINI/MAX TUBE CUTTER, 1/8"-1 1/8"	35
90735	TELESCOPING TUBE CUTTER, 1/4"-1 3/8"	35
90750	Q/R TUBE CUTTER, 1/4"-2 5/8"	35
90751	Q/R TUBING CUTTER, 2"-5"	35
90752	Q/R TUBE CUTTER, 4"-6 5/8"	35
95041	HINGED PIPE CUTTER, 2 1/2"-4"	7
95061	HINGED PIPE CUTTER, 4"-6"	7
95081	HINGED PIPE CUTTER, 6"-8"	7
95121	HINGED PIPE CUTTER, 8"-12"	7
98000	VALVEMASTER B&S ENGINE	52
98001	VALVEMASTER HONDA ENGINE	52
98002	VALVEMASTER B&S REVERSIBLE COUNTER	52
98003	VALVEMASTER HONDA REVERSIBLE COUNTER	52

Part No.	Description	Page
299010	HYDRAULIC PIPE CUTTER, 2"-10"	5
299012	HYDRAULIC PIPE CUTTER, 2"-12"	5
299015	HYDRAULIC PIPE CUTTER, 2"-15"	5
363020	FIRE HOSE TEST PUMP, 2 HOSE OUTLET	31
363040	FIRE HOSE TEST PUMP, 4 HOSE OUTLET	31
364540	HYDROSTATIC TEST PUMP 10 gpm 400 psi HONDA	29
389012	HYDRAULIC HD PIPE CUTTER, 4"-12"	5
389015	HYDRAULIC HD PIPE CUTTER, 4"-15"	5
389018	HYDRAULIC HD PIPE CUTTER, 4"-18"	5
389024	HYDRAULIC HD PIPE CUTTER, 4"-24"	5
400600	PIPE VISE W/LEGS, 3/4"-6"	45
401500	PIPE VISE W/LEGS, 3/4"-15"	45
402000	PIPE VISE W/LEGS, 3/4"-20"	45
402800	PIPE VISE W/LEGS, 3/4"-28"	45
462000	HYDROSTATIC TEST PUMP 3.5 gpm 1200 psi HONDA	29
463010	HYDROSTATIC TEST PUMP 10 gpm 500 psi HONDA	29
464530	HYDROSTATIC TEST PUMP 10 gpm 400 psi HONDA	29
465010	HYDROSTATIC TEST PUMP 10 gpm 500 psi HONDA	29
466000	HYDROSTATIC TEST PUMP 15 gpm 300 psi HONDA	30
467010	46501 TEST PUMP W/TANK 10 gpm 500 psi HONDA	30
468000	HYDROSTATIC TEST PUMP 26 gpm 250 psi HONDA	30
475190	CHAIN VISE UNIT FOR MANTIS	14
475192	FLAT VISE UNIT FOR MANTIS	14
559018	HYDRAULIC PIPE CUTTER, 6"-18"	5
559020	HYDRAULIC PIPE CUTTER, 6"-20"	5
559024	HYDRAULIC PIPE CUTTER, 6"-24"	5
559036	HYDRAULIC PIPE CUTTER, 6"-36"	5
562000	2" TRASH PUMP HONDA ENGINE	32
562001	562000 WITH WHEELED CART	32
563000	3" TRASH PUMP HONDA ENGINE	32
563001	563000 WITH WHEELED CART	32
563100	3" MUDSUCKER DIAPHRAGM PUMP	32
564000	4" TRASH PUMP 13HP HONDA ENGINE	32
681150	POWER DRIVE W/CLUTCH & COUNTER	52
681155	RISING STEM VALVE OPERATOR W/CTR & HAND WHEEL ADAPTER	52
700536	VACUUM TEST ASSEMBLY	31
700945	SET OF 4 RATCHCUTS W/CASE	34
701061	ELECTRONIC COUNTER ASSEMBLY FOR 681150	52
701185	BYPASS VALVE 6 GPM X 1500 psi	11
701186	BYPASS VALVE 8 GPM X 2000 psi	50
897065	UNIVERSAL DIE HEAD	27

WHEELER MANUFACTURING

Division of Rex International USA Inc.



Wheeler Manufacturing was established in 1957 with the invention of the chain type snap cutter for cast iron and clay tile pipes. It was a revolutionary tool which has since been adopted worldwide. This innovative product was followed by several other industry firsts, such as cutters for glass tube, power bevelers for PVC pipes, power torque wrenches for soil pipe couplings, shut off tools for copper and poly pipes, and sewer tapping machines. Today Wheeler-Rex sells worldwide with a wide variety of tools for the piping professional.

In 1988, Wheeler became part of the Rex Industries family. Rex Industries produces the highest quality and largest variety of pipe threading machines in the world. Rex has been an industry leader for over 75 years and has developed advanced features such as through the die head oiling, auto open die heads, notch type quick adjustments, and ball detent die location. Their quality is backed up by the best warranty in the business.

Wheeler-Rex products are sold exclusively through an extensive network of authorized distributors and service centers. To find your nearest location, contact Wheeler at 800-321-7950, Fax: 440-992-2925 or check out the website: www.wheelerrex.com.

Visit the Wheeler-Rex website

Product information,
tool parts breakdowns,
video clips and other
helpful information.



3D Design



www.wheelerrex.com



Expert Customer Service



CNC
Machining



98% of all orders are filled
within 2 working days



WHEELER MANUFACTURING
Division of Rex International U.S.A., Inc.

P.O. Box 688 • 3744 Jefferson Road • Ashtabula, Ohio 44005 U.S.A.

Tel: (440) 998-2788 • Toll-Free: 1-800-321-7950

Fax: (440) 992-2925 • www.wheelerrex.com • E-mail: wheeler@wheelerrex.com

Wheeler-Rex is UCC #662933



WHEELER REX



Wheeler Manufacturing

Division of Rex International U.S.A., Inc.

800-321-7950

Website: www.wheelerrex.com • E-mail: wheeler@wheelerrex.com

Issue 1